



**RETENES DE ACEITE**

Los retenes de aceite son juntas de estanqueidad para ejes rotativos. Se fabrican en una gran variedad de formas y materiales, según las condiciones de trabajo. En este catálogo se encuentra nuestra gama standard de retenes de aceite, si bien según la cantidad pueden suministrarse otras medidas, diseños o materiales.

El diseño básico del retén actual (**fig. 1**) se compone de un armazón metálico A que le da consistencia y que permite su montaje y fijación. Un labio de cierre B que es la única parte que estará sometida a movimiento relativo, y por tanto, sujeta a desgaste. Un muelle C que será el encargado de aportar un constante apriete entre el labio y el eje. Y finalmente, una membrana D, que es el elemento de más responsabilidad del conjunto, ya que todo eje rotativo está sometido a pequeñas pero constantes vibraciones.

Una vez obtenida la precisa tensión de contacto entre labio y eje, por medio del muelle que permite la formación de la película lubricante, estas vibraciones pueden, en momentos puntuales, incrementar el espesor de esta película hasta valores suficientes para permitir la fuga de aceite.



Figura 1

La única alternativa para evitar dicha fuga es que el espesor de la película se mantenga más o menos constante, por lo que la membrana debe tener la suficiente sensibilidad para “acompañar” al eje en sus vibraciones.

## LA FORMACIÓN DE LA PELÍCULA LUBRICANTE

Se forma a los pocos instantes de iniciarse el funcionamiento del retén, por efecto de la capilaridad, pero puede no producirse si el estado superficial del eje no es satisfactorio, o si el apriete del retén no es el adecuado.

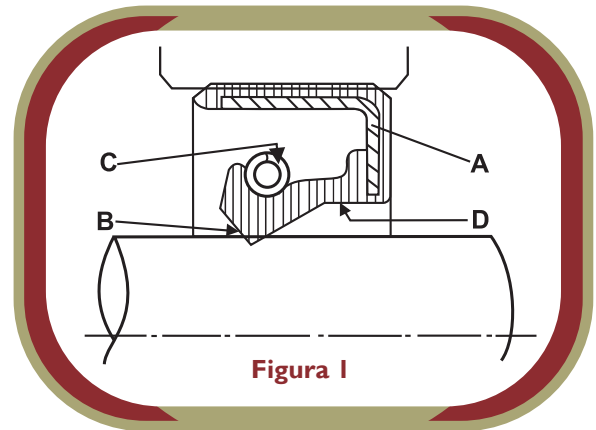
## INCREMENTO DE TEMPERATURA BAJO EL LABIO

Por efecto de la fricción, existe un incremento de temperatura en la zona inferior del labio.

Este incremento puede resultar negativo en la vida funcional del retén, pues podrá degradar rápidamente el material que lo compone. El aceite en este caso, actúa como agente disipador de calor, disminuyendo el salto térmico existente entre la zona bajo el labio y la temperatura del resto del aceite.

Por este motivo son muy importantes tanto las características propias del fluido, como la cantidad del mismo que esté en contacto con el retén.

En el **gráfico A** se pueden observar los incrementos de temperatura bajo el labio en relación a la temperatura del conjunto, en función del diámetro del eje a 3.000 rpm.

Asimismo, se puede ver como afecta el tipo de lubricante y su volumen en dicho incremento.

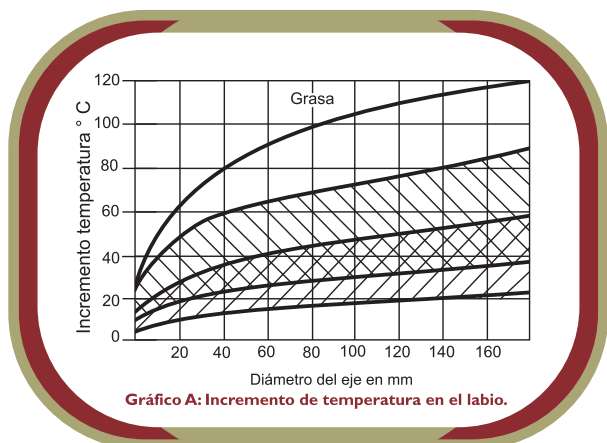

**Zona rayada**  es con aceite de transmisión tipo SAE 90.

**Zona rayada**  es con aceite de motor tipo SAE 20.

En ambas zonas la línea superior indica los valores en el caso de que el nivel del aceite apenas llegue a tocar el eje, y la línea inferior es cuando el retén está totalmente sumergido. También puede establecerse el incremento de la temperatura en función del diámetro del eje y de la velocidad de rotación (**gráfico B**).

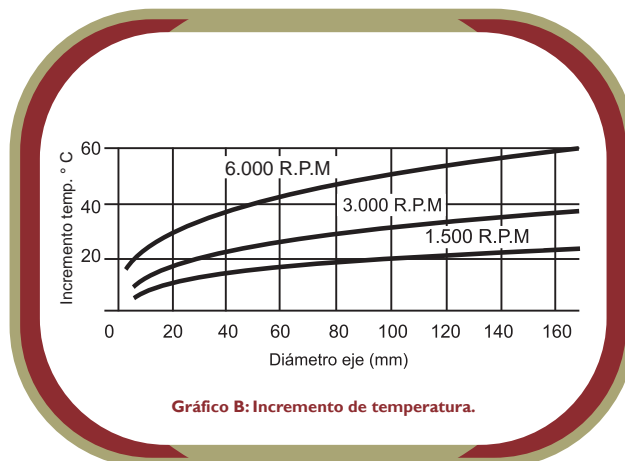

## EL EJE

### Material, acabados y tolerancias

El material adecuado para la fabricación del eje es acero o fundición, con una dureza superficial igual o mayor a 50 HRC. En el caso de aplicaciones especiales puede utilizarse el cromado duro o los casquillos de cerámica.

La mecanización debe realizarse con herramientas de avance frontal y el acabado superficial Ra debe ser 0,2 - 0,8 µm.

Se recomienda una tolerancia de medida del eje de ISO h11 (**ver tabla**)

| Diámetro eje (mm) | Tolerancia h 11 (mm) | Diámetro eje (mm) | Tolerancia h 11 (mm) |
|-------------------|----------------------|-------------------|----------------------|
| 6 ÷ 10            | + 0 - 0,09           | 80 ÷ 120          | + 0 - 0,22           |
| 10 ÷ 18           | + 0 - 0,11           | 120 ÷ 180         | + 0 - 0,25           |
| 18 ÷ 30           | + 0 - 0,13           | 180 ÷ 250         | + 0 - 0,29           |
| 30 ÷ 50           | + 0 - 0,16           | 250 ÷ 315         | + 0 - 0,32           |
| 50 ÷ 80           | + 0 - 0,19           | 315 ÷ 400         | + 0 - 0,36           |

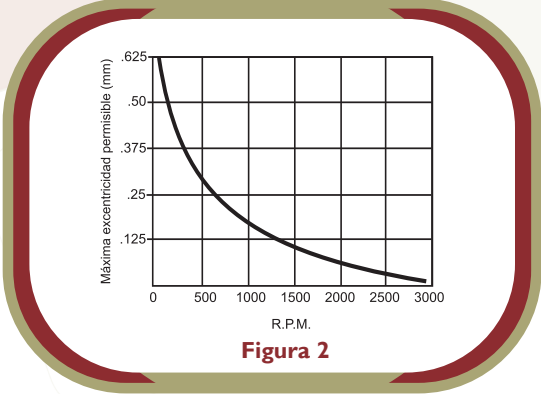

**Figura 2**

## Excentricidad y vibraciones

Es recomendable que el eje gire de forma concéntrica respecto al alojamiento del retén. El siguiente gráfico indica el valor máximo de excentricidad que pueden absorber los retenes a diferentes velocidades.

## CHAFLANES

Para facilitar el montaje y prevenir el deterioro del retén es conveniente que el eje disponga de un chaflán de entrada como se indica en la siguiente tabla.

| D <sub>1</sub><br>(mm) | D <sub>1</sub> - D <sub>2</sub><br>(mm) | D <sub>1</sub><br>(mm) | D <sub>1</sub> - D <sub>2</sub><br>(mm) |
|------------------------|---|------------------------|---|
| Hasta 10               | 1,5                                     | 50 : 70                | 4                                       |
| 10 ÷ 20                | 2                                       | 70 : 95                | 4,5                                     |
| 20 ÷ 30                | 2,5                                     | 95 : 130               | 5,5                                     |
| 30 ÷ 40                | 3                                       | 130 : 240              | 7                                       |
| 40 ÷ 50                | 3,5                                     | 240 : 400              | 11                                      |

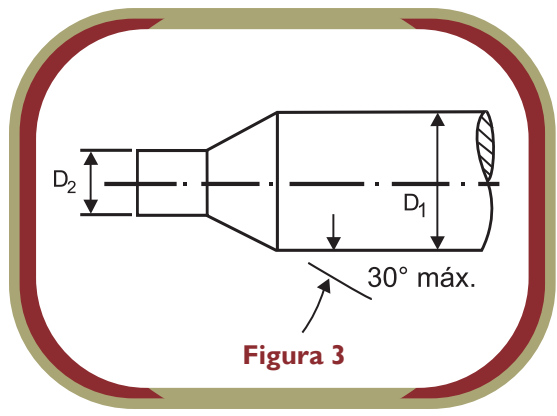

**Figura 3**

## ALOJAMIENTO

El alojamiento dónde debe instalarse el retén ha de mecanizarse con una tolerancia ISO H8 según tabla adjunta, cuidando de que no existan marcas longitudinales en la dirección del eje.

| MILÍMETROS           |                  |                      |                  | PULGADAS             |                  |
|----------------------|------------------|----------------------|------------------|----------------------|------------------|
| Diámetro Alojamiento | Tolerancia H8 mm | Diámetro Alojamiento | Tolerancia H8 mm | Diámetro Alojamiento | Tolerancia (+ -) |
| 6 ÷ 10               | + 0,022          | 50 ÷ 80              | + 0,046          | Hasta 4"             | + 0,001          |
| 10 ÷ 18              | + 0,027          | 80 ÷ 120             | + 0,054          | Desde 4,001 a 7"     | + 0,001          |
| 18 ÷ 30              | + 0,033          | 120 ÷ 180            | + 0,063          | Desde 4,001 a 7"     | + 0,001          |
| 30 ÷ 50              | + 0,039          | 180 ÷ 250            | + 0,072          | Desde 7,001"         | + 0,002          |

Es imprescindible prever un chaflán de entrada para facilitar el montaje del retén.

| Ø Aloj.   | Chaflan   | R máx |
|-----------|-----------|-------|
| Hasta 100 | 0,7 a 1   | 0,75  |
| Desde 100 | 1,2 a 1,5 | 1     |

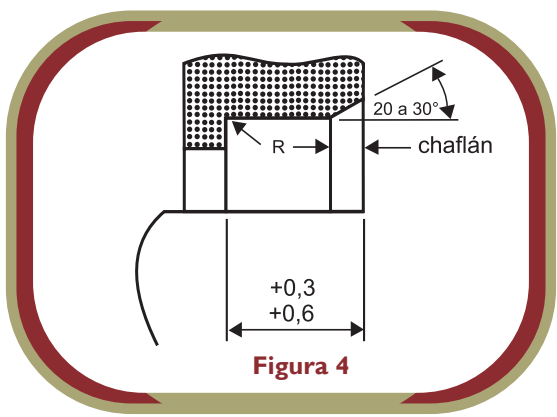

**Figura 4**

## MONTAJE

Para obtener un buen funcionamiento del retén, conviene prestar la máxima atención a los siguientes puntos:

- 1 Antes de instalar, examinar el retén para asegurarse de su estado de limpieza y que no presente ninguna irregularidad.
- 2 Aplicar grasa al labio del retén. Si tiene labio guardapolvo, poner grasa entre los dos labios.
- 3 Comprobar que el muelle esté bien asentado en su alojamiento.
- 4 Normalmente, el lado del muelle es el que debe estar encarado al aceite a retener.
- 5 Examinar el eje y eliminar cualquier rugosidad, restos de mecanizado, y en general cualquier impureza de su superficie. Los cantos deben ser redondeados o achaflanados. Caso de no ser posible, debe preverse un casquillo de montaje con bordes redondeados, y un diámetro exterior ligeramente superior al del eje (**fig.5**). Cualquier pequeño corte producido en el labio del retén en el momento de su montaje, será una fuga segura en el momento de funcionamiento.
- 6 Cuando se instala el retén en su alojamiento, debe realizarse con una presión uniforme en toda su circunferencia, cuidando además que su introducción sea totalmente perpendicular al eje.
- 7 Se recomienda la utilización de útiles de montaje del tipo reflejado en las **figuras 6 y 7**. El diámetro exterior del útil de montaje debe ser ligeramente inferior al del alojamiento (0,1 a 0,4 mm. más pequeño).
- 8 El diámetro exterior del retén debe haber sido engrasado previamente al montaje.

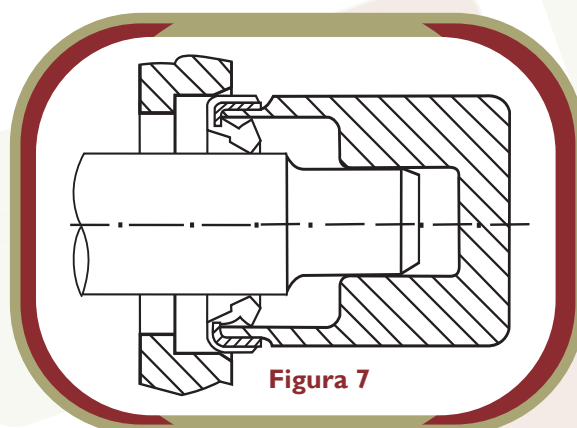
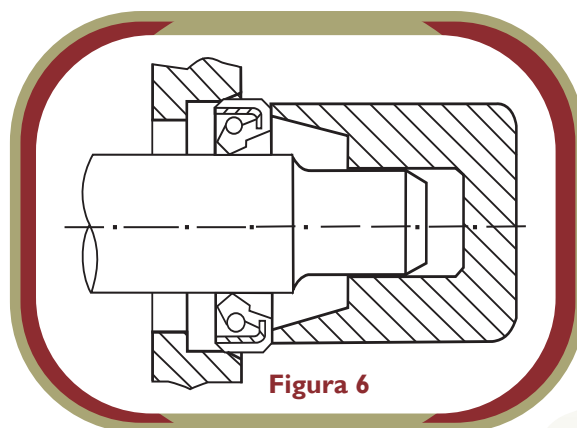
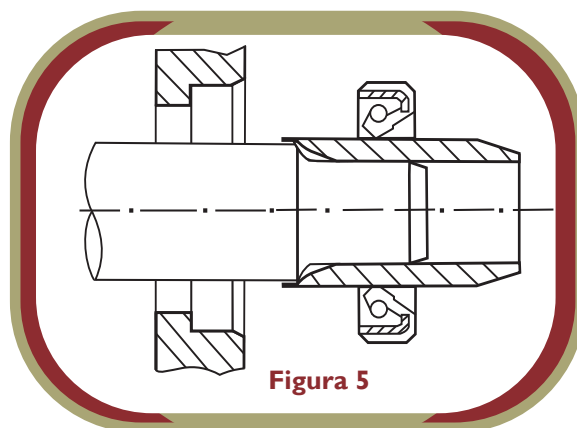

# PROGRAMA DE FABRICACIÓN

## A

Fabricado según norma DIN 3760 forma A. Alma metálica recubierta de goma.

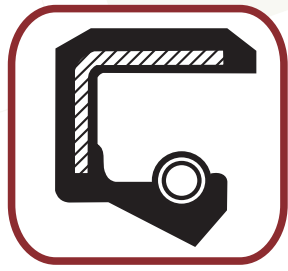

## AS

Igual al tipo A pero con la incorporación de un labio guardapolvo.



## B

Fabricado según norma DIN 3760 forma B. Carcasa exterior metálica.



## C

Fabricado según norma DIN 3760 forma C. Carcasa exterior metálica reforzada.



## DINA

Retén sin muelle de pared estrecha, especial para rodamientos.

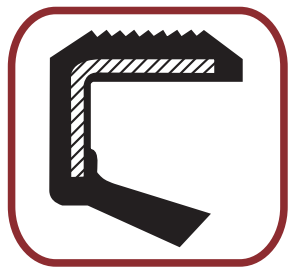

## D5

Retén sin alma metálica para puntos de aplicación en los que el montaje de retenes de una sola pieza sea problemático.



## A DUO

Retén de dos labios para estanqueizar dos fluidos diferentes.

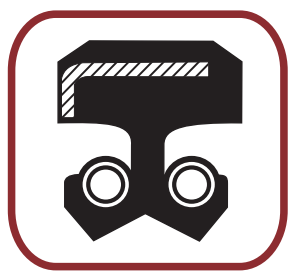

## AS P

Igual al tipo AS, preparado para soportar mayor presión.



Otros diseños bajo pedido.

## MATERIALES DE FABRICACIÓN

### Nitrilo

El caucho Nitrilo (NBR) tiene unas buenas propiedades mecánicas y una alta resistencia al desgaste. Es el material más utilizado para la fabricación de juntas. Compatible químicamente con aceites, grasas vegetales y minerales, agua, fluidos HFA, HFB y HFC, etc.

Su resistencia a la temperatura es de -30 a 100°C.

### FKM

El FKM tiene una excelente resistencia a altas temperaturas, aceites minerales, combustibles, fluidos hidráulicos sintéticos, oxígeno, ozono, etc. Resiste la mayoría de fluidos y lubricantes que destruyen el nitrilo o la silicona.

Adecuado para temperaturas de -15 a 200°C.

### Silicona

La Silicona (MVQ) tiene una muy buena resistencia a las altas y bajas temperaturas. Buen aislante, resistente a la intemperie y atóxica.

Adecuada para temperaturas de -60 a 200°C.

### PTFE

El PTFE tiene unas propiedades mecánicas y una resistencia química excepcionales. Dispone de un coeficiente de rozamiento muy bajo y permite altas velocidades.

Adecuado para temperaturas de -50 a 270°C.

**A****AS****B****C****DINA****D5****A DUO****AS P**

| Referencia | Ø int. | Ø ext. | Altura | Material |
|------------|--------|--------|--------|----------|
|------------|--------|--------|--------|----------|

|      |      |       |      |     |
|------|------|-------|------|-----|
| DINA | 4    | 8     | 2    | NBR |
| A    | 4    | 11    | 6    | FKM |
| A    | 4    | 16    | 4    | NBR |
| A    | 5    | 15    | 6    | NBR |
| A    | 5    | 16    | 6    | NBR |
| A    | 5    | 16    | 7    | FKM |
| DINA | 6    | 10    | 2    | NBR |
| B    | 6    | 11    | 4,5  | NBR |
| DINA | 6    | 12    | 1    | NBR |
| A    | 6    | 14    | 6    | NBR |
| A    | 6    | 14    | 6    | FKM |
| A    | 6    | 15    | 4    | NBR |
| A    | 6    | 15    | 4    | FKM |
| A    | 6    | 16    | 6    | FKM |
| A    | 6    | 16    | 7    | NBR |
| A    | 6    | 16    | 7    | FKM |
| A    | 6    | 19    | 6    | NBR |
| A    | 6    | 19    | 6    | FKM |
| A    | 6    | 19    | 7    | NBR |
| A    | 6    | 20    | 6    | FKM |
| A    | 6    | 21    | 7    | NBR |
| A    | 6    | 22    | 7    | NBR |
| A    | 6    | 22    | 7    | FKM |
| A    | 6,35 | 19,05 | 6,35 | FKM |
| A    | 7    | 16    | 7    | NBR |
| A    | 7    | 16    | 7    | FKM |
| A    | 7    | 22    | 7    | NBR |
| A    | 7    | 22    | 7    | FKM |
| DINA | 8    | 12    | 3    | NBR |
| DINA | 8    | 15    | 3    | NBR |
| A    | 8    | 16    | 7    | NBR |
| A    | 8    | 16    | 7    | FKM |
| A    | 8    | 18    | 5    | FKM |
| A    | 8    | 22    | 7    | NBR |
| AS   | 8    | 22    | 7    | NBR |
| A    | 8    | 22    | 7    | FKM |
| AS   | 8    | 22    | 7    | FKM |
| A    | 8    | 24    | 7    | NBR |
| A    | 8    | 24    | 7    | FKM |
| A    | 9    | 16    | 4    | NBR |
| AS P | 9    | 20    | 6    | NBR |
| A    | 9    | 22    | 7    | NBR |
| A    | 9    | 22    | 7    | FKM |
| A    | 9    | 24    | 7    | NBR |
| A    | 9    | 24    | 7    | FKM |
| A    | 9    | 26    | 7    | NBR |
| A    | 9,52 | 22,22 | 6,35 | NBR |
| DINA | 10   | 14    | 3    | NBR |
| DINA | 10   | 17    | 3    | NBR |

| Referencia | Ø int. | Ø ext. | Altura | Material |
|------------|--------|--------|--------|----------|
|------------|--------|--------|--------|----------|

|      |       |       |      |     |
|------|-------|-------|------|-----|
| AS   | 10    | 18    | 4    | NBR |
| A    | 10    | 19    | 7    | NBR |
| A    | 10    | 19    | 7    | FKM |
| A    | 10    | 22    | 6    | NBR |
| AS P | 10    | 22    | 6    | NBR |
| A    | 10    | 22    | 7    | NBR |
| A    | 10    | 22    | 7    | FKM |
| A    | 10    | 24    | 7    | NBR |
| A    | 10    | 24    | 7    | FKM |
| A    | 10    | 26    | 7    | NBR |
| A    | 10    | 28    | 7    | FKM |
| A    | 10    | 28    | 8    | FKM |
| A    | 10    | 30    | 7    | NBR |
| A    | 10    | 30    | 7    | FKM |
| A    | 11    | 22    | 7    | NBR |
| A    | 11    | 22    | 7    | FKM |
| A    | 11    | 26    | 7    | NBR |
| AS   | 11    | 30    | 7    | NBR |
| DINA | 12    | 16    | 3    | NBR |
| DINA | 12    | 18    | 3    | NBR |
| DINA | 12    | 19    | 3    | NBR |
| A    | 12    | 19    | 5    | NBR |
| A    | 12    | 19    | 5    | FKM |
| AS   | 12    | 20    | 5    | NBR |
| A    | 12    | 22    | 4    | FKM |
| A    | 12    | 22    | 4,5  | FKM |
| A    | 12    | 22    | 5    | NBR |
| A    | 12    | 22    | 7    | NBR |
| A    | 12    | 22    | 7    | FKM |
| AS   | 12    | 22    | 7    | FKM |
| A    | 12    | 24    | 6,5  | FKM |
| A    | 12    | 24    | 7    | NBR |
| AS   | 12    | 24    | 7    | NBR |
| A    | 12    | 24    | 7    | FKM |
| A    | 12    | 26    | 8    | NBR |
| A    | 12    | 28    | 7    | NBR |
| A    | 12    | 28    | 7    | FKM |
| A    | 12    | 30    | 7    | NBR |
| A    | 12    | 30    | 7    | FKM |
| A    | 12    | 32    | 7    | NBR |
| A    | 12,45 | 26,97 | 6,35 | NBR |
| A    | 12,5  | 20    | 5    | NBR |
| A    | 12,5  | 20    | 6    | NBR |
| AS   | 12,7  | 22,23 | 6,35 | NBR |
| A    | 12,7  | 25,4  | 4,76 | FKM |
| A    | 12,7  | 26    | 6    | NBR |
| A    | 12,7  | 31,75 | 9,52 | FKM |
| A    | 13    | 22    | 5    | NBR |
| A    | 13    | 30    | 7    | FKM |



A



AS



B



C



DINA



D5



A DUO



AS P

| Referencia | Ø int. | Ø ext. | Altura | Material |
|------------|--------|--------|--------|----------|
|------------|--------|--------|--------|----------|

|       |    |    |     |     |
|-------|----|----|-----|-----|
| AS    | 13 | 30 | 7   | NBR |
| A     | 13 | 35 | 10  | NBR |
| DINA  | 14 | 20 | 3   | NBR |
| DINA  | 14 | 21 | 3   | NBR |
| A     | 14 | 22 | 4   | NBR |
| A     | 14 | 22 | 4   | FKM |
| A     | 14 | 24 | 7   | NBR |
| AS    | 14 | 24 | 7   | NBR |
| A     | 14 | 24 | 7   | FKM |
| AS    | 14 | 25 | 7   | NBR |
| A     | 14 | 27 | 7   | FKM |
| A     | 14 | 28 | 7   | NBR |
| A     | 14 | 30 | 7   | NBR |
| A     | 14 | 30 | 7   | FKM |
| A     | 14 | 35 | 7   | NBR |
| DINA  | 15 | 21 | 3   | NBR |
| DINA  | 15 | 23 | 3   | NBR |
| A     | 15 | 24 | 5   | NBR |
| A     | 15 | 24 | 5   | FKM |
| A     | 15 | 24 | 7   | NBR |
| AS    | 15 | 24 | 7   | NBR |
| A     | 15 | 24 | 7   | FKM |
| AS    | 15 | 24 | 7   | FKM |
| A     | 15 | 25 | 5   | NBR |
| AS    | 15 | 25 | 7   | NBR |
| A     | 15 | 26 | 7   | NBR |
| AS    | 15 | 26 | 7   | NBR |
| A     | 15 | 27 | 7   | NBR |
| A     | 15 | 28 | 7   | FKM |
| A DUO | 15 | 28 | 7   | NBR |
| A     | 15 | 30 | 4,5 | NBR |
| A     | 15 | 30 | 4,5 | FKM |
| A     | 15 | 30 | 7   | NBR |
| A     | 15 | 30 | 7   | FKM |
| A     | 15 | 30 | 10  | FKM |
| A     | 15 | 32 | 7   | NBR |
| A     | 15 | 32 | 7   | FKM |
| A     | 15 | 35 | 5   | NBR |
| AS P  | 15 | 35 | 6   | NBR |
| A     | 15 | 35 | 7   | NBR |
| AS    | 15 | 35 | 7   | NBR |
| A     | 15 | 35 | 7   | FKM |
| A     | 15 | 35 | 8   | NBR |
| A     | 15 | 35 | 10  | NBR |
| A     | 15 | 37 | 7   | FKM |
| A     | 15 | 40 | 10  | NBR |
| A     | 15 | 42 | 7   | NBR |
| A     | 15 | 42 | 7   | FKM |
| A DUO | 15 | 42 | 10  | NBR |

| Referencia | Ø int. | Ø ext. | Altura | Material |
|------------|--------|--------|--------|----------|
|------------|--------|--------|--------|----------|

|       |       |       |      |     |
|-------|-------|-------|------|-----|
| A     | 15,88 | 28,58 | 6,35 | FKM |
| DINA  | 16    | 22    | 3    | NBR |
| A     | 16    | 22    | 4    | NBR |
| DINA  | 16    | 24    | 3    | NBR |
| A     | 16    | 24    | 4    | FKM |
| A     | 16    | 24    | 5    | NBR |
| A     | 16    | 26    | 7    | NBR |
| A     | 16    | 26    | 7    | FKM |
| A     | 16    | 28    | 7    | NBR |
| AS    | 16    | 28    | 7    | NBR |
| A     | 16    | 28    | 7    | FKM |
| AS    | 16    | 28    | 7    | FKM |
| A     | 16    | 30    | 7    | NBR |
| A     | 16    | 30    | 7    | FKM |
| A     | 16    | 32    | 7    | NBR |
| A     | 16    | 35    | 7    | NBR |
| DINA  | 17    | 23    | 3    | NBR |
| A     | 17    | 26    | 6    | NBR |
| A     | 17    | 26    | 6    | FKM |
| A     | 17    | 28    | 6    | NBR |
| AS    | 17    | 28    | 6    | FKM |
| A     | 17    | 28    | 7    | NBR |
| AS    | 17    | 28    | 7    | NBR |
| A     | 17    | 28    | 7    | FKM |
| AS    | 17    | 28    | 7    | FKM |
| A     | 17    | 28    | 8    | NBR |
| A     | 17    | 28    | 8    | FKM |
| A DUO | 17    | 28    | 8    | FKM |
| A     | 17    | 30    | 7    | NBR |
| A     | 17    | 30    | 7    | FKM |
| A     | 17    | 32    | 7    | NBR |
| A     | 17    | 32    | 7    | FKM |
| A     | 17    | 32    | 10   | FKM |
| A     | 17    | 35    | 7    | NBR |
| A     | 17    | 35    | 7    | FKM |
| A     | 17    | 35    | 8    | NBR |
| A     | 17    | 35    | 10   | NBR |
| A     | 17    | 35    | 10   | FKM |
| A     | 17    | 40    | 7    | NBR |
| AS    | 17    | 40    | 7    | NBR |
| A     | 17    | 40    | 7    | FKM |
| A     | 17    | 40    | 8,5  | NBR |
| A     | 17    | 40    | 10   | NBR |
| A     | 17    | 47    | 7    | FKM |
| AS    | 17    | 47    | 10   | NBR |
| A     | 17,27 | 28,44 | 9,52 | FKM |
| DINA  | 18    | 24    | 4    | NBR |
| DINA  | 18    | 26    | 4    | NBR |
| A     | 18    | 28    | 6    | FKM |

**A****AS****B****C****DINA****D5****A DUO****AS P**

| Referencia | Ø int. | Ø ext. | Altura | Material |
|------------|--------|--------|--------|----------|
|------------|--------|--------|--------|----------|

|      |       |       |     |     |
|------|-------|-------|-----|-----|
| A    | 18    | 28    | 7   | NBR |
| AS   | 18    | 28    | 7   | NBR |
| A    | 18    | 28    | 7   | FKM |
| A    | 18    | 28    | 8   | FKM |
| A    | 18    | 30    | 5   | NBR |
| AS   | 18    | 30    | 6   | NBR |
| A    | 18    | 30    | 7   | NBR |
| A    | 18    | 30    | 7   | FKM |
| AS   | 18    | 30    | 7   | FKM |
| A    | 18    | 32    | 5   | FKM |
| A    | 18    | 32    | 7   | NBR |
| A    | 18    | 32    | 7   | FKM |
| A    | 18    | 35    | 7   | NBR |
| A P  | 18    | 35    | 10  | NBR |
| A    | 18    | 40    | 7   | NBR |
| A    | 18    | 40    | 7   | FKM |
| AS P | 19    | 27,2  | 5   | NBR |
| AS   | 19    | 28    | 6   | NBR |
| AS   | 19    | 32    | 7   | NBR |
| A    | 19    | 47    | 10  | NBR |
| AS   | 19,05 | 31,75 | 6,3 | FKM |
| AS   | 19,05 | 31,75 | 6,3 | NBR |
| DINA | 20    | 26    | 4   | NBR |
| DINA | 20    | 28    | 4   | NBR |
| AS   | 20    | 28    | 7   | NBR |
| A    | 20    | 30    | 5   | NBR |
| A    | 20    | 30    | 5   | FKM |
| A    | 20    | 30    | 7   | NBR |
| AS   | 20    | 30    | 7   | NBR |
| A    | 20    | 30    | 7   | FKM |
| AS   | 20    | 30    | 7   | FKM |
| A    | 20    | 32    | 7   | NBR |
| AS   | 20    | 32    | 7   | NBR |
| A    | 20    | 32    | 7   | FKM |
| A    | 20    | 33    | 10  | FKM |
| AS P | 20    | 35    | 6   | NBR |
| AS P | 20    | 35    | 6   | FKM |
| A    | 20    | 35    | 7   | NBR |
| AS   | 20    | 35    | 7   | NBR |
| A    | 20    | 35    | 7   | FKM |
| AS   | 20    | 35    | 8   | NBR |
| A    | 20    | 35    | 10  | NBR |
| A    | 20    | 35    | 10  | FKM |
| A    | 20    | 38    | 7   | NBR |
| A    | 20    | 38    | 8   | FKM |
| A    | 20    | 40    | 7   | NBR |
| A    | 20    | 40    | 7   | FKM |
| AS   | 20    | 40    | 7   | FKM |
| A    | 20    | 40    | 10  | NBR |

| Referencia | Ø int. | Ø ext. | Altura | Material |
|------------|--------|--------|--------|----------|
|------------|--------|--------|--------|----------|

|      |       |       |      |     |
|------|-------|-------|------|-----|
| A    | 20    | 40    | 10   | FKM |
| A    | 20    | 42    | 7    | NBR |
| AS   | 20    | 42    | 7    | NBR |
| A    | 20    | 42    | 7    | FKM |
| AS   | 20    | 42    | 7    | FKM |
| A    | 20    | 42    | 10   | NBR |
| A    | 20    | 42    | 10   | FKM |
| AS   | 20    | 45    | 7    | NBR |
| A    | 20    | 47    | 7    | NBR |
| A    | 20    | 47    | 7    | FKM |
| A    | 20    | 47    | 10   | NBR |
| A    | 20    | 47    | 10   | FKM |
| A    | 20    | 48,4  | 7    | NBR |
| A    | 20    | 52    | 7    | FKM |
| B    | 20    | 55    | 10   | FKM |
| AS   | 20,63 | 30,16 | 4,6  | NBR |
| A    | 21    | 28    | 4    | NBR |
| DINA | 21    | 29    | 4    | NBR |
| AS   | 21    | 40    | 7    | NBR |
| B    | 21,3  | 55    | 10   | FKM |
| DINA | 22    | 28    | 4    | NBR |
| DINA | 22    | 30    | 4    | NBR |
| A    | 22    | 32    | 5,5  | NBR |
| A P  | 22    | 32    | 5,6  | FKM |
| A    | 22    | 32    | 7    | NBR |
| A    | 22    | 32    | 7    | FKM |
| A    | 22    | 35    | 4,2  | FKM |
| AS   | 22    | 35    | 4,2  | FKM |
| A    | 22    | 35    | 7    | NBR |
| AS   | 22    | 35    | 7    | NBR |
| A    | 22    | 35    | 7    | FKM |
| AS   | 22    | 35    | 7    | FKM |
| A    | 22    | 35    | 8    | FKM |
| A    | 22    | 35    | 10   | NBR |
| A    | 22    | 36    | 7    | NBR |
| A    | 22    | 38    | 7    | FKM |
| A    | 22    | 38    | 7    | NBR |
| AS   | 22    | 38    | 10   | NBR |
| A    | 22    | 40    | 7    | NBR |
| AS   | 22    | 40    | 7    | NBR |
| A    | 22    | 40    | 7    | FKM |
| AS   | 22    | 40    | 7    | FKM |
| A    | 22    | 40    | 10   | FKM |
| A    | 22    | 47    | 7    | NBR |
| A    | 22    | 47    | 7    | FKM |
| AS   | 22    | 47    | 10   | NBR |
| A    | 22,23 | 35,15 | 9,5  | FKM |
| AS   | 22,23 | 35,15 | 9,5  | FKM |
| A    | 23,81 | 36,51 | 6,35 | NBR |

**A****AS****B****C****DINA****D5****A DUO****AS P**

| Referencia | Ø int. | Ø ext. | Altura | Material |
|------------|--------|--------|--------|----------|
|------------|--------|--------|--------|----------|

|       |       |       |      |     |
|-------|-------|-------|------|-----|
| A     | 23,81 | 36,51 | 6,35 | FKM |
| DINA  | 24    | 32    | 4    | NBR |
| A     | 24    | 35    | 6    | FKM |
| A     | 24    | 35    | 7    | NBR |
| A     | 24    | 35    | 7    | FKM |
| AS    | 24    | 36    | 7    | NBR |
| A     | 24    | 36    | 7    | FKM |
| AS    | 24    | 36    | 7    | FKM |
| A     | 24    | 37    | 7    | NBR |
| A     | 24    | 38,5  | 10   | FKM |
| A     | 24    | 40    | 7    | NBR |
| AS    | 24    | 40    | 7    | NBR |
| A     | 24    | 40    | 7    | FKM |
| A     | 24    | 40    | 10   | NBR |
| AS    | 24    | 42    | 7    | NBR |
| AS    | 24    | 45    | 7    | NBR |
| A     | 24    | 47    | 7    | NBR |
| AS    | 24    | 47    | 10   | NBR |
| A     | 24,5  | 40    | 8,5  | NBR |
| A     | 24,5  | 40    | 8,5  | FKM |
| DINA  | 25    | 32    | 4    | NBR |
| DINA  | 25    | 32    | 4    | FKM |
| A     | 25    | 32    | 6    | FKM |
| A     | 25    | 32    | 7    | NBR |
| DINA  | 25    | 33    | 4    | NBR |
| A     | 25    | 33    | 6    | NBR |
| A     | 25    | 33    | 6    | FKM |
| DINA  | 25    | 35    | 4    | NBR |
| AS    | 25    | 35    | 5    | NBR |
| AS P  | 25    | 35    | 6    | NBR |
| AS    | 25    | 35    | 6    | NBR |
| AS P  | 25    | 35    | 6    | FKM |
| A     | 25    | 35    | 7    | NBR |
| AS    | 25    | 35    | 7    | NBR |
| A     | 25    | 35    | 7    | FKM |
| AS    | 25    | 35    | 7    | FKM |
| A DUO | 25    | 35    | 8    | NBR |
| A     | 25    | 37    | 5    | NBR |
| A     | 25    | 37    | 5    | FKM |
| AS    | 25    | 37    | 7    | NBR |
| AS    | 25    | 37    | 8    | NBR |
| A     | 25    | 38    | 7    | NBR |
| A     | 25    | 38    | 7    | FKM |
| A     | 25    | 40    | 5    | FKM |
| A     | 25    | 40    | 7    | NBR |
| AS    | 25    | 40    | 7    | NBR |
| A     | 25    | 40    | 7    | FKM |
| AS    | 25    | 40    | 7    | FKM |
| A     | 25    | 40    | 8    | NBR |

| Referencia | Ø int. | Ø ext. | Altura | Material |
|------------|--------|--------|--------|----------|
|------------|--------|--------|--------|----------|

|       |      |       |      |     |
|-------|------|-------|------|-----|
| AS    | 25   | 40    | 8    | NBR |
| A DUO | 25   | 40    | 8    | FKM |
| A     | 25   | 40    | 10   | NBR |
| A     | 25   | 40    | 10   | FKM |
| A     | 25   | 42    | 7    | NBR |
| AS    | 25   | 42    | 7    | NBR |
| A     | 25   | 42    | 7    | FKM |
| AS    | 25   | 42    | 7    | FKM |
| A     | 25   | 42    | 8,5  | NBR |
| A     | 25   | 42    | 10   | NBR |
| A     | 25   | 42    | 10   | FKM |
| A     | 25   | 45    | 7    | NBR |
| A     | 25   | 45    | 10   | NBR |
| A     | 25   | 45    | 10   | FKM |
| A     | 25   | 46    | 7    | NBR |
| A     | 25   | 47    | 7    | NBR |
| A     | 25   | 47    | 8    | FKM |
| A     | 25   | 47    | 10   | NBR |
| A     | 25   | 47    | 10   | FKM |
| A DUO | 25   | 47    | 12   | NBR |
| A     | 25   | 50    | 7    | FKM |
| A     | 25   | 50    | 8    | NBR |
| AS    | 25   | 50    | 10   | NBR |
| A     | 25   | 50    | 10   | FKM |
| A     | 25   | 52    | 7    | NBR |
| AS    | 25   | 52    | 7    | NBR |
| A     | 25   | 52    | 7    | FKM |
| AS    | 25   | 52    | 7    | FKM |
| A     | 25   | 52    | 8    | NBR |
| A     | 25   | 52    | 10   | NBR |
| A     | 25   | 52    | 10   | FKM |
| B     | 25   | 54    | 10   | NBR |
| A     | 25   | 62    | 7    | FKM |
| A     | 25   | 62    | 10   | NBR |
| A     | 25   | 62    | 10   | FKM |
| AS    | 25,4 | 44,45 | 9,52 | FKM |
| A     | 25,4 | 44,45 | 9,52 | NBR |
| B     | 25,4 | 55    | 10   | FKM |
| A     | 26   | 35    | 4    | NBR |
| A     | 26   | 35    | 7    | NBR |
| A     | 26   | 36    | 7    | FKM |
| A     | 26   | 37    | 7    | NBR |
| AS    | 26   | 37    | 7    | NBR |
| A     | 26   | 42    | 7    | NBR |
| AS    | 26   | 42    | 7    | FKM |
| A     | 26   | 47    | 7    | NBR |
| A     | 26   | 47    | 7    | FKM |
| A     | 26   | 52    | 10   | NBR |
| AS    | 26   | 52    | 10   | NBR |



A



AS



B



C



DINA



D5



A DUO



AS P

| Referencia | ∅ int. | ∅ ext. | Altura | Material |
|------------|--------|--------|--------|----------|
|------------|--------|--------|--------|----------|

|       |       |       |       |     |
|-------|-------|-------|-------|-----|
| AS    | 26    | 52    | 10    | FKM |
| A     | 26,99 | 47,63 | 9,53  | FKM |
| A     | 27    | 37    | 7     | NBR |
| A     | 27    | 37    | 7     | FKM |
| A     | 27    | 41    | 10    | FKM |
| DINA  | 28    | 35    | 4     | NBR |
| DINA  | 28    | 37    | 4     | NBR |
| A     | 28    | 38    | 7     | NBR |
| AS    | 28    | 38    | 7     | NBR |
| A     | 28    | 38    | 7     | FKM |
| A     | 28    | 40    | 7     | NBR |
| A     | 28    | 40    | 7     | FKM |
| A     | 28    | 40    | 10    | FKM |
| A     | 28    | 42    | 7     | NBR |
| A     | 28    | 42    | 10    | NBR |
| A     | 28    | 42    | 10    | FKM |
| A     | 28    | 45    | 7     | FKM |
| AS    | 28    | 45    | 8     | NBR |
| A     | 28    | 45    | 9     | FKM |
| A     | 28    | 47    | 7     | NBR |
| A     | 28    | 47    | 7     | FKM |
| AS    | 28    | 47    | 7     | FKM |
| A     | 28    | 47    | 10    | NBR |
| A     | 28    | 47    | 10    | FKM |
| AS    | 28    | 47    | 10    | FKM |
| A     | 28    | 50    | 10    | NBR |
| AS    | 28    | 50    | 10    | NBR |
| A     | 28    | 50    | 10    | FKM |
| A     | 28    | 52    | 7     | NBR |
| A     | 28    | 52    | 7     | FKM |
| AS    | 28    | 52    | 7     | FKM |
| A     | 28    | 52    | 10    | NBR |
| AS    | 28    | 70    | 10    | NBR |
| A     | 28,57 | 41,27 | 9,52  | FKM |
| AS    | 28,57 | 41,27 | 9,52  | NBR |
| B     | 28,57 | 47    | 7     | FKM |
| A     | 28,57 | 50,8  | 11,11 | FKM |
| A     | 29    | 40    | 7     | NBR |
| AS    | 29    | 46    | 10    | NBR |
| DINA  | 30    | 37    | 4     | NBR |
| A     | 30    | 40    | 4     | NBR |
| DINA  | 30    | 40    | 4     | NBR |
| A     | 30    | 40    | 5     | NBR |
| A     | 30    | 40    | 5     | FKM |
| A     | 30    | 40    | 7     | NBR |
| AS    | 30    | 40    | 7     | NBR |
| A     | 30    | 40    | 7     | FKM |
| A     | 30    | 40    | 8     | NBR |
| A DUO | 30    | 40    | 8     | NBR |

| Referencia | ∅ int. | ∅ ext. | Altura | Material |
|------------|--------|--------|--------|----------|
|------------|--------|--------|--------|----------|

|      |    |    |    |     |
|------|----|----|----|-----|
| AS P | 30 | 42 | 6  | NBR |
| A    | 30 | 42 | 7  | NBR |
| AS   | 30 | 42 | 7  | NBR |
| A    | 30 | 42 | 7  | FKM |
| AS   | 30 | 42 | 7  | FKM |
| AS   | 30 | 42 | 8  | NBR |
| A    | 30 | 44 | 10 | NBR |
| A    | 30 | 45 | 7  | FKM |
| A    | 30 | 45 | 8  | NBR |
| A    | 30 | 45 | 8  | FKM |
| A    | 30 | 45 | 10 | NBR |
| A    | 30 | 45 | 10 | FKM |
| AS   | 30 | 46 | 7  | NBR |
| A    | 30 | 47 | 6  | NBR |
| A    | 30 | 47 | 7  | NBR |
| AS P | 30 | 47 | 7  | NBR |
| A    | 30 | 47 | 7  | FKM |
| AS   | 30 | 47 | 7  | FKM |
| A    | 30 | 47 | 8  | FKM |
| A    | 30 | 47 | 10 | NBR |
| A    | 30 | 47 | 10 | FKM |
| A    | 30 | 48 | 8  | NBR |
| A    | 30 | 50 | 7  | NBR |
| A    | 30 | 50 | 10 | NBR |
| AS   | 30 | 50 | 10 | NBR |
| A    | 30 | 50 | 10 | FKM |
| A    | 30 | 52 | 5  | FKM |
| A    | 30 | 52 | 7  | NBR |
| AS   | 30 | 52 | 7  | NBR |
| A    | 30 | 52 | 7  | FKM |
| A    | 30 | 52 | 10 | NBR |
| AS   | 30 | 52 | 10 | NBR |
| A    | 30 | 52 | 10 | FKM |
| AS   | 30 | 52 | 10 | FKM |
| A    | 30 | 55 | 7  | NBR |
| A    | 30 | 55 | 10 | NBR |
| AS   | 30 | 55 | 10 | NBR |
| A    | 30 | 55 | 10 | FKM |
| AS   | 30 | 55 | 10 | FKM |
| A    | 30 | 56 | 10 | FKM |
| A    | 30 | 60 | 10 | NBR |
| A    | 30 | 62 | 7  | NBR |
| AS   | 30 | 62 | 7  | NBR |
| A    | 30 | 62 | 7  | FKM |
| A    | 30 | 62 | 10 | NBR |
| A    | 30 | 62 | 10 | FKM |
| AS   | 30 | 72 | 8  | FKM |
| A    | 30 | 72 | 10 | NBR |
| A    | 30 | 85 | 10 | NBR |



A



AS



B



C



DINA



D5



A DUO



AS P

| Referencia | Ø int. | Ø ext. | Altura | Material |
|------------|--------|--------|--------|----------|
|------------|--------|--------|--------|----------|

|       |       |       |      |     |
|-------|-------|-------|------|-----|
| A     | 30,16 | 44,45 | 6,35 | FKM |
| A     | 31    | 47    | 7    | FKM |
| AS    | 31,75 | 41,27 | 6,35 | FKM |
| A     | 31,75 | 44,45 | 9,52 | FKM |
| A DUO | 31,75 | 44,45 | 9,52 | FKM |
| DINA  | 32    | 42    | 4    | NBR |
| A     | 32    | 42    | 7    | NBR |
| AS    | 32    | 44    | 8    | NBR |
| DINA  | 32    | 45    | 4    | NBR |
| A     | 32    | 45    | 7    | NBR |
| A     | 32    | 45    | 7    | FKM |
| A     | 32    | 45    | 10   | FKM |
| A     | 32    | 47    | 6    | FKM |
| A     | 32    | 47    | 7    | NBR |
| A     | 32    | 47    | 7    | FKM |
| AS    | 32    | 47    | 10   | NBR |
| A     | 32    | 48    | 8    | FKM |
| A     | 32    | 50    | 8    | NBR |
| A     | 32    | 50    | 10   | NBR |
| A     | 32    | 50    | 10   | FKM |
| A     | 32    | 52    | 7    | NBR |
| AS    | 32    | 52    | 7    | NBR |
| A     | 32    | 52    | 7    | FKM |
| A     | 32    | 52    | 10   | NBR |
| A     | 32    | 52    | 10   | FKM |
| AS    | 32    | 54    | 10   | NBR |
| AS    | 32    | 56    | 10   | NBR |
| A     | 32    | 57    | 9,5  | FKM |
| A     | 32    | 62    | 10   | NBR |
| A     | 32    | 70    | 8    | NBR |
| A     | 32    | 70    | 8    | FKM |
| A     | 33    | 45    | 7    | NBR |
| A     | 33    | 45    | 7    | FKM |
| A     | 33    | 50    | 8    | NBR |
| B     | 33,4  | 55    | 10   | FKM |
| A     | 34    | 44    | 7    | FKM |
| AS    | 34    | 48    | 7    | NBR |
| A     | 34    | 49    | 8    | FKM |
| A     | 34    | 50    | 10   | NBR |
| A     | 34    | 52    | 7,5  | FKM |
| A     | 34    | 52    | 8    | NBR |
| A     | 34    | 52    | 10   | NBR |
| A     | 34    | 55    | 10   | FKM |
| A     | 34,92 | 60,32 | 12,7 | NBR |
| DINA  | 35    | 42    | 4    | NBR |
| DINA  | 35    | 42    | 4    | FKM |
| A     | 35    | 44    | 7    | FKM |
| DINA  | 35    | 45    | 4    | NBR |
| A     | 35    | 45    | 7    | NBR |

| Referencia | Ø int. | Ø ext. | Altura | Material |
|------------|--------|--------|--------|----------|
|------------|--------|--------|--------|----------|

|      |    |      |     |     |
|------|----|------|-----|-----|
| AS   | 35 | 45   | 7   | NBR |
| A    | 35 | 45   | 7   | FKM |
| A    | 35 | 45   | 10  | NBR |
| A    | 35 | 47   | 4,5 | NBR |
| A    | 35 | 47   | 6   | FKM |
| A    | 35 | 47   | 7   | NBR |
| AS   | 35 | 47   | 7   | NBR |
| A    | 35 | 47   | 7   | FKM |
| AS   | 35 | 47   | 7   | FKM |
| AS P | 35 | 47   | 10  | NBR |
| A    | 35 | 50   | 7   | NBR |
| A    | 35 | 50   | 7   | FKM |
| A    | 35 | 50   | 8   | FKM |
| A    | 35 | 50   | 10  | NBR |
| A    | 35 | 50   | 10  | FKM |
| AS   | 35 | 52   | 5,5 | FKM |
| AS   | 35 | 52   | 6   | NBR |
| AS   | 35 | 52   | 6   | FKM |
| A    | 35 | 52   | 7   | NBR |
| AS   | 35 | 52   | 7   | NBR |
| A    | 35 | 52   | 7   | FKM |
| A    | 35 | 52   | 10  | NBR |
| A    | 35 | 52   | 10  | FKM |
| AS   | 35 | 52   | 10  | FKM |
| A    | 35 | 53   | 8   | NBR |
| A    | 35 | 54   | 10  | FKM |
| A    | 35 | 54   | 10  | NBR |
| AS   | 35 | 55   | 8   | NBR |
| A    | 35 | 55   | 10  | NBR |
| AS   | 35 | 55   | 10  | NBR |
| A    | 35 | 55   | 10  | FKM |
| AS   | 35 | 55   | 10  | FKM |
| A    | 35 | 55,5 | 9   | NBR |
| A    | 35 | 56   | 10  | NBR |
| AS   | 35 | 56   | 10  | NBR |
| A    | 35 | 56   | 10  | FKM |
| A    | 35 | 60   | 10  | NBR |
| A    | 35 | 62   | 7   | NBR |
| AS P | 35 | 62   | 7   | NBR |
| A    | 35 | 62   | 7   | FKM |
| A    | 35 | 62   | 10  | NBR |
| AS   | 35 | 62   | 10  | NBR |
| A    | 35 | 62   | 10  | FKM |
| A    | 35 | 62   | 10  | FKM |
| A    | 35 | 67   | 7   | NBR |
| A    | 35 | 68   | 6   | FKM |
| AS   | 35 | 68   | 10  | NBR |
| A    | 35 | 68   | 10  | FKM |
| A    | 35 | 72   | 10  | NBR |
| AS   | 35 | 72   | 10  | NBR |

**A****AS****B****C****DINA****D5****A DUO****AS P**

| Referencia | ∅ int. | ∅ ext. | Altura | Material |
|------------|--------|--------|--------|----------|
|------------|--------|--------|--------|----------|

|      |      |       |      |     |
|------|------|-------|------|-----|
| A    | 35   | 72    | 10   | FKM |
| AS   | 35   | 80    | 10   | NBR |
| A    | 36   | 47    | 7    | NBR |
| A    | 36   | 48    | 10   | FKM |
| A    | 36   | 50    | 7    | NBR |
| A    | 36   | 50    | 7    | FKM |
| A    | 36   | 50    | 10   | NBR |
| A    | 36   | 50    | 10   | FKM |
| AS   | 36   | 52    | 6    | FKM |
| A    | 36   | 52    | 7    | NBR |
| AS   | 36   | 52    | 7    | FKM |
| A    | 36   | 54    | 7,5  | FKM |
| A    | 36   | 54    | 8    | NBR |
| A    | 36   | 62    | 7    | NBR |
| AS   | 36   | 62    | 7    | FKM |
| DINA | 37   | 47    | 4    | NBR |
| A    | 37   | 52    | 10   | FKM |
| DINA | 38   | 48    | 4    | NBR |
| A    | 38   | 50    | 7    | NBR |
| A    | 38   | 50    | 7    | FKM |
| A    | 38   | 52    | 7    | NBR |
| AS   | 38   | 52    | 7    | NBR |
| A    | 38   | 52    | 7    | FKM |
| AS   | 38   | 52    | 7    | FKM |
| AS   | 38   | 52    | 10   | NBR |
| A    | 38   | 54    | 6,5  | FKM |
| A    | 38   | 55    | 7    | NBR |
| A    | 38   | 55    | 10   | NBR |
| B    | 38   | 55    | 10   | FKM |
| A    | 38   | 56    | 10   | FKM |
| A    | 38   | 60    | 10   | FKM |
| A    | 38   | 62    | 7    | NBR |
| AS   | 38   | 62    | 7    | NBR |
| AS   | 38   | 62    | 7    | FKM |
| A    | 38   | 62    | 10   | NBR |
| A    | 38   | 62    | 10   | FKM |
| AS   | 38   | 62    | 10   | FKM |
| A    | 38   | 65    | 8    | FKM |
| A    | 38   | 72    | 10   | NBR |
| A    | 38,1 | 50,29 | 12,7 | NBR |
| DINA | 40   | 47    | 4    | NBR |
| A    | 40   | 50    | 4    | NBR |
| DINA | 40   | 50    | 4    | NBR |
| AS   | 40   | 50    | 7    | NBR |
| DINA | 40   | 52    | 5    | NBR |
| A    | 40   | 52    | 6    | FKM |
| A    | 40   | 52    | 7    | NBR |
| AS   | 40   | 52    | 7    | NBR |
| A    | 40   | 52    | 7    | FKM |

| Referencia | ∅ int. | ∅ ext. | Altura | Material |
|------------|--------|--------|--------|----------|
|------------|--------|--------|--------|----------|

|      |    |    |    |     |
|------|----|----|----|-----|
| AS   | 40 | 52 | 7  | FKM |
| AS   | 40 | 55 | 6  | FKM |
| A    | 40 | 55 | 7  | NBR |
| AS   | 40 | 55 | 7  | NBR |
| A    | 40 | 55 | 7  | FKM |
| AS P | 40 | 55 | 7  | FKM |
| A    | 40 | 55 | 8  | NBR |
| AS   | 40 | 55 | 8  | NBR |
| A    | 40 | 55 | 8  | FKM |
| AS   | 40 | 55 | 8  | FKM |
| B    | 40 | 55 | 8  | NBR |
| A    | 40 | 55 | 10 | NBR |
| A    | 40 | 56 | 8  | NBR |
| AS   | 40 | 56 | 8  | NBR |
| A    | 40 | 56 | 8  | FKM |
| A    | 40 | 56 | 10 | FKM |
| A    | 40 | 58 | 8  | NBR |
| A    | 40 | 58 | 10 | NBR |
| A    | 40 | 58 | 10 | FKM |
| A    | 40 | 60 | 10 | NBR |
| AS   | 40 | 60 | 10 | NBR |
| A    | 40 | 60 | 10 | FKM |
| AS   | 40 | 60 | 12 | NBR |
| AS P | 40 | 62 | 6  | NBR |
| A    | 40 | 62 | 7  | NBR |
| AS   | 40 | 62 | 7  | NBR |
| A    | 40 | 62 | 7  | FKM |
| AS   | 40 | 62 | 7  | FKM |
| A    | 40 | 62 | 10 | NBR |
| AS   | 40 | 62 | 10 | NBR |
| A    | 40 | 62 | 10 | FKM |
| A    | 40 | 63 | 10 | NBR |
| A    | 40 | 65 | 10 | NBR |
| A    | 40 | 65 | 10 | FKM |
| AS   | 40 | 65 | 12 | NBR |
| A    | 40 | 68 | 8  | NBR |
| A    | 40 | 68 | 10 | NBR |
| A    | 40 | 68 | 10 | FKM |
| AS   | 40 | 68 | 10 | FKM |
| A    | 40 | 70 | 10 | NBR |
| A    | 40 | 72 | 7  | NBR |
| A    | 40 | 72 | 7  | FKM |
| A    | 40 | 72 | 10 | NBR |
| A    | 40 | 72 | 10 | FKM |
| AS   | 40 | 72 | 10 | FKM |
| A    | 40 | 80 | 10 | NBR |
| AS   | 40 | 80 | 10 | NBR |
| A    | 40 | 80 | 10 | FKM |
| AS   | 40 | 80 | 10 | FKM |



A



AS



B



C



DINA



D5



A DUO



AS P

| Referencia | Ø int. | Ø ext. | Altura | Material |
|------------|--------|--------|--------|----------|
|------------|--------|--------|--------|----------|

|      |       |       |      |     |
|------|-------|-------|------|-----|
| AS   | 40    | 80    | 12   | NBR |
| A    | 40    | 85    | 10   | FKM |
| A    | 40    | 90    | 10   | NBR |
| AS   | 40    | 90    | 12   | FKM |
| A    | 40,08 | 50,85 | 4,1  | NBR |
| AS   | 41,28 | 63,5  | 12,7 | NBR |
| DINA | 42    | 52    | 4    | NBR |
| A    | 42    | 55    | 7    | NBR |
| AS   | 42    | 55    | 7    | FKM |
| A    | 42    | 55    | 8    | NBR |
| A    | 42    | 55    | 8    | FKM |
| B    | 42    | 55    | 8    | NBR |
| A    | 42    | 56    | 7    | NBR |
| AS   | 42    | 56    | 7    | NBR |
| A    | 42    | 56    | 7    | FKM |
| A    | 42    | 58    | 7    | NBR |
| A    | 42    | 58    | 10   | NBR |
| A    | 42    | 60    | 10   | NBR |
| A    | 42    | 60    | 12   | FKM |
| A    | 42    | 62    | 7    | NBR |
| A    | 42    | 62    | 7    | FKM |
| A    | 42    | 62    | 8    | NBR |
| A    | 42    | 62    | 8    | FKM |
| AS   | 42    | 62    | 8    | FKM |
| A    | 42    | 62    | 10   | NBR |
| A    | 42    | 62    | 10   | FKM |
| A    | 42    | 65    | 10   | NBR |
| A    | 42    | 65    | 10   | FKM |
| AS   | 42    | 66    | 8    | NBR |
| A    | 42    | 72    | 7    | NBR |
| A    | 42    | 72    | 8    | NBR |
| A    | 42    | 72    | 10   | NBR |
| A    | 42    | 72    | 10   | FKM |
| A    | 42    | 80    | 10   | NBR |
| B    | 42,8  | 80    | 10   | FKM |
| DINA | 43    | 53    | 4    | NBR |
| A    | 43    | 70    | 12   | FKM |
| AS   | 44    | 62    | 10   | NBR |
| A    | 44    | 65    | 10   | FKM |
| B    | 44    | 80    | 10   | FKM |
| A    | 44,45 | 63,5  | 9,52 | FKM |
| DINA | 45    | 52    | 4    | NBR |
| A    | 45    | 55    | 4    | NBR |
| DINA | 45    | 55    | 4    | NBR |
| A    | 45    | 55    | 7    | NBR |
| A    | 45    | 55    | 7    | FKM |
| AS   | 45    | 57    | 9    | NBR |
| AS   | 45    | 58    | 7    | NBR |
| A    | 45    | 60    | 7    | NBR |

| Referencia | Ø int. | Ø ext. | Altura | Material |
|------------|--------|--------|--------|----------|
|------------|--------|--------|--------|----------|

|      |    |    |    |     |
|------|----|----|----|-----|
| A    | 45 | 60 | 7  | FKM |
| A    | 45 | 60 | 8  | NBR |
| A    | 45 | 60 | 8  | FKM |
| A    | 45 | 60 | 10 | NBR |
| A    | 45 | 60 | 10 | FKM |
| AS P | 45 | 62 | 7  | NBR |
| A    | 45 | 62 | 7  | FKM |
| AS   | 45 | 62 | 7  | FKM |
| A    | 45 | 62 | 8  | NBR |
| A    | 45 | 62 | 8  | FKM |
| AS   | 45 | 62 | 8  | FKM |
| A    | 45 | 62 | 10 | NBR |
| A    | 45 | 62 | 10 | FKM |
| A    | 45 | 62 | 12 | FKM |
| A    | 45 | 65 | 8  | NBR |
| AS   | 45 | 65 | 8  | NBR |
| A    | 45 | 65 | 8  | FKM |
| A    | 45 | 65 | 10 | NBR |
| AS   | 45 | 65 | 10 | NBR |
| A    | 45 | 65 | 10 | FKM |
| A    | 45 | 66 | 6  | FKM |
| A    | 45 | 66 | 10 | NBR |
| A    | 45 | 68 | 10 | NBR |
| A    | 45 | 68 | 10 | FKM |
| A    | 45 | 70 | 12 | FKM |
| A    | 45 | 72 | 7  | NBR |
| A    | 45 | 72 | 8  | NBR |
| AS   | 45 | 72 | 8  | NBR |
| A    | 45 | 72 | 8  | FKM |
| AS   | 45 | 72 | 8  | FKM |
| A    | 45 | 72 | 10 | NBR |
| A    | 45 | 72 | 10 | FKM |
| A    | 45 | 72 | 12 | NBR |
| A    | 45 | 75 | 8  | NBR |
| AS   | 45 | 75 | 8  | NBR |
| A    | 45 | 75 | 10 | FKM |
| AS   | 45 | 75 | 10 | FKM |
| A    | 45 | 80 | 10 | NBR |
| AS   | 45 | 80 | 10 | NBR |
| A    | 45 | 80 | 10 | FKM |
| AS   | 45 | 80 | 10 | FKM |
| A    | 45 | 80 | 13 | NBR |
| A    | 45 | 85 | 10 | NBR |
| AS   | 45 | 85 | 10 | NBR |
| AS   | 45 | 85 | 10 | FKM |
| AS   | 46 | 60 | 10 | NBR |
| A    | 46 | 64 | 8  | NBR |
| AS   | 46 | 64 | 14 | NBR |
| A    | 47 | 58 | 6  | NBR |

**A****AS****B****C****DINA****D5****A DUO****AS P**

| Referencia | ∅ int. | ∅ ext. | Altura | Material |
|------------|--------|--------|--------|----------|
|------------|--------|--------|--------|----------|

|      |       |       |      |     |
|------|-------|-------|------|-----|
| A    | 47    | 58    | 6    | FKM |
| A    | 47    | 80    | 10   | FKM |
| A    | 47,63 | 69,85 | 12,7 | FKM |
| AS   | 48    | 58    | 4    | NBR |
| A    | 48    | 62    | 8    | NBR |
| A    | 48    | 62    | 8    | FKM |
| A    | 48    | 65    | 10   | NBR |
| AS   | 48    | 65    | 10   | NBR |
| A    | 48    | 65    | 10   | FKM |
| AS   | 48    | 65    | 10   | FKM |
| AS   | 48    | 68    | 10   | NBR |
| B    | 48    | 68    | 10   | FKM |
| AS   | 48    | 70    | 10   | NBR |
| A    | 48    | 72    | 8    | NBR |
| A    | 48    | 72    | 8    | FKM |
| AS   | 48    | 72    | 8    | FKM |
| A    | 48    | 72    | 10   | NBR |
| A    | 48    | 72    | 10   | FKM |
| AS   | 48    | 72    | 12   | NBR |
| A    | 48    | 80    | 10   | NBR |
| A    | 48    | 80    | 10   | FKM |
| A    | 49    | 65    | 10   | NBR |
| AS   | 49,2  | 76,2  | 12,7 | NBR |
| B    | 49,22 | 69,85 | 9,52 | NBR |
| DINA | 50    | 58    | 4    | NBR |
| A    | 50    | 60    | 7    | FKM |
| A    | 50    | 62    | 5    | NBR |
| DINA | 50    | 62    | 5    | NBR |
| A    | 50    | 62    | 7    | FKM |
| A    | 50    | 62    | 10   | NBR |
| A    | 50    | 65    | 8    | NBR |
| AS   | 50    | 65    | 8    | NBR |
| A    | 50    | 65    | 8    | FKM |
| AS   | 50    | 65    | 8    | FKM |
| A    | 50    | 65    | 10   | NBR |
| A    | 50    | 68    | 8    | NBR |
| AS   | 50    | 68    | 8    | NBR |
| A    | 50    | 68    | 8    | FKM |
| AS   | 50    | 68    | 8    | FKM |
| A    | 50    | 68    | 10   | NBR |
| AS   | 50    | 68    | 10   | NBR |
| A    | 50    | 68    | 10   | FKM |
| A    | 50    | 70    | 10   | NBR |
| AS   | 50    | 70    | 10   | NBR |
| A    | 50    | 70    | 10   | FKM |
| A    | 50    | 70    | 12   | FKM |
| AS P | 50    | 72    | 7    | NBR |
| AS   | 50    | 72    | 7    | FKM |
| A    | 50    | 72    | 8    | NBR |

| Referencia | ∅ int. | ∅ ext. | Altura | Material |
|------------|--------|--------|--------|----------|
|------------|--------|--------|--------|----------|

|       |       |       |      |     |
|-------|-------|-------|------|-----|
| A     | 50    | 72    | 8    | FKM |
| AS    | 50    | 72    | 8    | FKM |
| A     | 50    | 72    | 10   | NBR |
| AS    | 50    | 72    | 10   | NBR |
| A     | 50    | 72    | 10   | FKM |
| AS    | 50    | 72    | 10   | FKM |
| AS    | 50    | 72    | 12   | NBR |
| A     | 50    | 72    | 12   | FKM |
| A DUO | 50    | 72    | 14   | NBR |
| B     | 50    | 75    | 10   | FKM |
| AS    | 50    | 75    | 12   | NBR |
| A     | 50    | 80    | 8    | NBR |
| AS    | 50    | 80    | 8    | NBR |
| A     | 50    | 80    | 8    | FKM |
| AS    | 50    | 80    | 8    | FKM |
| A     | 50    | 80    | 10   | NBR |
| A     | 50    | 80    | 10   | FKM |
| AS    | 50    | 80    | 13   | FKM |
| AS    | 50    | 80    | 13   | NBR |
| A     | 50    | 90    | 10   | NBR |
| AS    | 50    | 90    | 10   | NBR |
| A     | 50    | 90    | 10   | FKM |
| A     | 50,8  | 63,5  | 6,35 | FKM |
| A     | 50,8  | 69,85 | 9,52 | FKM |
| A     | 52    | 62    | 8    | NBR |
| A     | 52    | 62    | 8    | FKM |
| A     | 52    | 68    | 8    | NBR |
| A     | 52    | 68    | 8    | FKM |
| A     | 52    | 69    | 10   | FKM |
| A     | 52    | 72    | 8    | NBR |
| A     | 52    | 72    | 8    | FKM |
| AS    | 52    | 72    | 8    | FKM |
| A     | 52    | 72    | 10   | FKM |
| AS    | 52    | 72    | 12   | NBR |
| A     | 52    | 75    | 12   | NBR |
| A     | 52    | 75    | 12   | FKM |
| A     | 52    | 85    | 10   | NBR |
| A     | 53,97 | 79,37 | 12,7 | FKM |
| A     | 54    | 70    | 12   | FKM |
| A     | 54    | 72    | 12   | FKM |
| A     | 54    | 74    | 8    | NBR |
| AS    | 54    | 81    | 10   | NBR |
| AS    | 54    | 85    | 10   | NBR |
| A     | 54    | 85    | 10   | FKM |
| A     | 54    | 90    | 10   | FKM |
| A     | 54    | 90    | 13   | NBR |
| A     | 54    | 90    | 13   | FKM |
| DINA  | 55    | 63    | 5    | NBR |
| A     | 55    | 68    | 8    | FKM |



A



AS



B



C



DINA



D5



A DUO



AS P

| Referencia | Ø int. | Ø ext. | Altura | Material |
|------------|--------|--------|--------|----------|
|------------|--------|--------|--------|----------|

|    |       |       |      |     |
|----|-------|-------|------|-----|
| A  | 55    | 70    | 8    | NBR |
| A  | 55    | 70    | 8    | FKM |
| AS | 55    | 70    | 8    | FKM |
| A  | 55    | 70    | 10   | NBR |
| A  | 55    | 70    | 10   | FKM |
| A  | 55    | 72    | 8    | NBR |
| AS | 55    | 72    | 8    | NBR |
| A  | 55    | 72    | 8    | FKM |
| AS | 55    | 72    | 8    | FKM |
| A  | 55    | 72    | 10   | NBR |
| A  | 55    | 72    | 10   | FKM |
| AS | 55    | 72    | 10   | FKM |
| A  | 55    | 75    | 10   | NBR |
| A  | 55    | 75    | 10   | FKM |
| A  | 55    | 75    | 12   | NBR |
| A  | 55    | 75    | 12   | FKM |
| AS | 55    | 78    | 12   | FKM |
| A  | 55    | 80    | 6    | NBR |
| A  | 55    | 80    | 8    | NBR |
| A  | 55    | 80    | 8    | FKM |
| A  | 55    | 80    | 10   | NBR |
| A  | 55    | 80    | 10   | FKM |
| AS | 55    | 80    | 10   | FKM |
| A  | 55    | 85    | 8    | NBR |
| AS | 55    | 85    | 10   | NBR |
| A  | 55    | 90    | 8    | NBR |
| AS | 55    | 90    | 8    | NBR |
| A  | 55    | 90    | 10   | NBR |
| A  | 55    | 90    | 10   | FKM |
| A  | 55    | 100   | 12   | NBR |
| A  | 55    | 100   | 13   | NBR |
| AS | 56    | 69    | 10   | NBR |
| A  | 56    | 70    | 8    | NBR |
| A  | 56    | 70    | 8    | FKM |
| A  | 56    | 72    | 8    | NBR |
| A  | 56    | 80    | 8    | NBR |
| A  | 56    | 80    | 12   | FKM |
| A  | 56    | 85    | 8    | NBR |
| A  | 56    | 85    | 8    | FKM |
| A  | 56    | 90    | 10   | NBR |
| B  | 57    | 80    | 10   | FKM |
| A  | 57,15 | 82,55 | 12,7 | FKM |
| A  | 57,94 | 84,93 | 7,93 | NBR |
| A  | 58    | 72    | 8    | NBR |
| A  | 58    | 72    | 8    | FKM |
| A  | 58    | 72    | 10   | FKM |
| A  | 58    | 72    | 10   | NBR |
| A  | 58    | 75    | 8    | FKM |
| A  | 58    | 75    | 10   | NBR |

| Referencia | Ø int. | Ø ext. | Altura | Material |
|------------|--------|--------|--------|----------|
|------------|--------|--------|--------|----------|

|       |    |     |    |     |
|-------|----|-----|----|-----|
| A     | 58 | 78  | 13 | FKM |
| A     | 58 | 80  | 8  | NBR |
| A     | 58 | 80  | 8  | FKM |
| AS    | 58 | 80  | 9  | FKM |
| A     | 58 | 80  | 10 | NBR |
| AS    | 58 | 80  | 10 | NBR |
| A     | 58 | 80  | 10 | FKM |
| AS P  | 58 | 80  | 10 | FKM |
| A     | 58 | 90  | 10 | NBR |
| A     | 60 | 70  | 7  | NBR |
| A     | 60 | 72  | 8  | FKM |
| A     | 60 | 75  | 8  | NBR |
| AS    | 60 | 75  | 8  | NBR |
| A     | 60 | 75  | 8  | FKM |
| AS    | 60 | 75  | 8  | FKM |
| A     | 60 | 75  | 10 | FKM |
| A     | 60 | 78  | 10 | FKM |
| A     | 60 | 80  | 5  | NBR |
| AS    | 60 | 80  | 7  | NBR |
| AS P  | 60 | 80  | 7  | FKM |
| A     | 60 | 80  | 8  | NBR |
| A     | 60 | 80  | 8  | FKM |
| AS    | 60 | 80  | 8  | FKM |
| A     | 60 | 80  | 10 | NBR |
| AS    | 60 | 80  | 10 | NBR |
| A     | 60 | 80  | 10 | FKM |
| AS    | 60 | 80  | 10 | FKM |
| A DUO | 60 | 80  | 10 | NBR |
| A     | 60 | 80  | 12 | NBR |
| A     | 60 | 80  | 12 | FKM |
| AS    | 60 | 80  | 12 | FKM |
| A     | 60 | 80  | 13 | NBR |
| A     | 60 | 82  | 12 | NBR |
| A     | 60 | 85  | 8  | NBR |
| A     | 60 | 85  | 8  | FKM |
| A     | 60 | 85  | 10 | NBR |
| AS    | 60 | 85  | 10 | NBR |
| A     | 60 | 85  | 10 | FKM |
| AS    | 60 | 85  | 10 | FKM |
| AS    | 60 | 85  | 12 | NBR |
| A     | 60 | 90  | 8  | NBR |
| A     | 60 | 90  | 8  | FKM |
| A     | 60 | 90  | 10 | NBR |
| A     | 60 | 90  | 10 | FKM |
| AS    | 60 | 90  | 10 | FKM |
| A     | 60 | 90  | 13 | FKM |
| A     | 60 | 95  | 10 | FKM |
| A     | 60 | 95  | 12 | FKM |
| A     | 60 | 110 | 13 | NBR |



A



AS



B



C



DINA



D5



A DUO



AS P

| Referencia | Ø int. | Ø ext. | Altura | Material |
|------------|--------|--------|--------|----------|
|------------|--------|--------|--------|----------|

|    |       |       |       |     |
|----|-------|-------|-------|-----|
| A  | 60    | 110   | 13    | FKM |
| A  | 61,91 | 95,73 | 12,7  | FKM |
| A  | 62    | 76    | 10    | FKM |
| AS | 62    | 80    | 10    | NBR |
| A  | 62    | 80    | 10    | FKM |
| A  | 62    | 85    | 10    | NBR |
| A  | 62    | 85    | 10    | FKM |
| AS | 62    | 85    | 12    | NBR |
| A  | 62    | 85    | 12    | FKM |
| A  | 62    | 90    | 10    | NBR |
| A  | 62    | 95    | 10    | NBR |
| A  | 62    | 100   | 12    | NBR |
| A  | 62    | 110   | 13    | NBR |
| AS | 63    | 80    | 9     | NBR |
| A  | 63    | 85    | 10    | NBR |
| A  | 63    | 85    | 10    | FKM |
| AS | 63    | 85    | 10    | FKM |
| A  | 63    | 90    | 10    | NBR |
| A  | 63,5  | 73,03 | 6,35  | FKM |
| A  | 63,5  | 82,55 | 9,52  | FKM |
| A  | 63,5  | 88,9  | 11,11 | FKM |
| A  | 64    | 80    | 8     | NBR |
| A  | 65    | 80    | 8     | NBR |
| A  | 65    | 80    | 8     | FKM |
| AS | 65    | 80    | 8     | FKM |
| AS | 65    | 80    | 10    | NBR |
| AS | 65    | 80    | 10    | FKM |
| A  | 65    | 85    | 5     | NBR |
| A  | 65    | 85    | 8     | FKM |
| A  | 65    | 85    | 10    | NBR |
| AS | 65    | 85    | 10    | NBR |
| A  | 65    | 85    | 10    | FKM |
| A  | 65    | 85    | 12    | NBR |
| AS | 65    | 85    | 13    | FKM |
| A  | 65    | 90    | 10    | NBR |
| AS | 65    | 90    | 10    | NBR |
| A  | 65    | 90    | 10    | FKM |
| AS | 65    | 90    | 10    | FKM |
| AS | 65    | 90    | 12    | NBR |
| A  | 65    | 95    | 10    | NBR |
| A  | 65    | 95    | 10    | FKM |
| AS | 65    | 95    | 13    | NBR |
| A  | 65    | 100   | 10    | NBR |
| AS | 65    | 100   | 10    | NBR |
| A  | 65    | 100   | 10    | FKM |
| A  | 65    | 125   | 12    | NBR |
| A  | 65,08 | 85,72 | 9,5   | NBR |
| A  | 66,68 | 85,73 | 9,53  | FKM |
| A  | 66,68 | 92,02 | 11,9  | FKM |

| Referencia | Ø int. | Ø ext. | Altura | Material |
|------------|--------|--------|--------|----------|
|------------|--------|--------|--------|----------|

|       |       |      |      |     |
|-------|-------|------|------|-----|
| A     | 68    | 90   | 10   | NBR |
| AS    | 68    | 90   | 10   | NBR |
| A     | 68    | 90   | 10   | FKM |
| AS    | 68    | 90   | 10   | FKM |
| A     | 68    | 100  | 10   | NBR |
| A     | 68    | 100  | 10   | FKM |
| A     | 69,85 | 88,9 | 9,53 | FKM |
| DINA  | 70    | 78   | 5    | NBR |
| A     | 70    | 85   | 7    | FKM |
| A     | 70    | 85   | 8    | NBR |
| A     | 70    | 85   | 8    | FKM |
| A     | 70    | 85   | 10   | NBR |
| A     | 70    | 88   | 9    | FKM |
| A     | 70    | 90   | 5    | NBR |
| AS P  | 70    | 90   | 7    | NBR |
| AS    | 70    | 90   | 7    | NBR |
| A     | 70    | 90   | 10   | NBR |
| AS    | 70    | 90   | 10   | NBR |
| A     | 70    | 90   | 10   | FKM |
| AS    | 70    | 90   | 10   | FKM |
| A DUO | 70    | 90   | 10   | FKM |
| A     | 70    | 90   | 12   | NBR |
| A     | 70    | 90   | 12   | FKM |
| A     | 70    | 90   | 13   | FKM |
| A DUO | 70    | 90   | 13   | FKM |
| A     | 70    | 92   | 12   | NBR |
| A     | 70    | 95   | 10   | NBR |
| A     | 70    | 95   | 10   | FKM |
| A     | 70    | 95   | 13   | NBR |
| AS    | 70    | 100  | 8    | FKM |
| A     | 70    | 100  | 10   | NBR |
| AS    | 70    | 100  | 10   | NBR |
| A     | 70    | 100  | 10   | FKM |
| AS    | 70    | 100  | 10   | FKM |
| A     | 70    | 100  | 12   | FKM |
| A     | 70    | 100  | 13   | FKM |
| AS    | 70    | 110  | 10   | NBR |
| A     | 70    | 110  | 10   | FKM |
| A     | 70    | 110  | 12   | NBR |
| A     | 70    | 120  | 12   | NBR |
| AS    | 71    | 88   | 8    | NBR |
| A     | 72    | 85   | 10   | NBR |
| A     | 72    | 85   | 10   | FKM |
| A     | 72    | 90   | 10   | NBR |
| A     | 72    | 90   | 10   | FKM |
| A     | 72    | 95   | 10   | NBR |
| A     | 72    | 95   | 10   | FKM |
| A     | 72    | 95   | 12   | NBR |
| AS    | 72    | 95   | 13   | NBR |

**A****AS****B****C****DINA****D5****A DUO****AS P**

| Referencia | Ø int. | Ø ext. | Altura | Material |
|------------|--------|--------|--------|----------|
|------------|--------|--------|--------|----------|

|       |       |        |      |     |
|-------|-------|--------|------|-----|
| AS    | 72    | 96     | 9    | NBR |
| A     | 72    | 100    | 10   | NBR |
| A     | 72    | 110    | 12   | NBR |
| B     | 73    | 95     | 10   | FKM |
| A     | 75    | 90     | 8    | NBR |
| AS    | 75    | 90     | 8    | NBR |
| A     | 75    | 90     | 8    | FKM |
| A     | 75    | 90     | 10   | NBR |
| A     | 75    | 90     | 10   | FKM |
| A     | 75    | 95     | 5    | NBR |
| AS    | 75    | 95     | 9    | NBR |
| A     | 75    | 95     | 10   | NBR |
| A     | 75    | 95     | 10   | FKM |
| AS    | 75    | 95     | 10   | FKM |
| A     | 75    | 95     | 12   | NBR |
| A     | 75    | 95     | 12   | FKM |
| A     | 75    | 95     | 13   | NBR |
| A     | 75    | 100    | 10   | NBR |
| AS    | 75    | 100    | 10   | NBR |
| A     | 75    | 100    | 10   | FKM |
| AS    | 75    | 100    | 10   | FKM |
| A     | 75    | 100    | 12   | FKM |
| A     | 75    | 100    | 13   | NBR |
| A     | 75    | 105    | 12   | NBR |
| A     | 75    | 110    | 12   | NBR |
| AS    | 75    | 110    | 12   | NBR |
| A     | 75    | 110    | 12   | FKM |
| A     | 75    | 110    | 13   | FKM |
| A     | 75    | 120    | 12   | NBR |
| A     | 76,2  | 107,95 | 12,7 | FKM |
| A     | 77,78 | 114,3  | 12,7 | FKM |
| A     | 78    | 100    | 10   | NBR |
| A     | 78    | 100    | 10   | FKM |
| A     | 78    | 110    | 12   | NBR |
| A     | 78    | 110    | 12   | FKM |
| A     | 80    | 95     | 8    | NBR |
| A     | 80    | 100    | 7    | NBR |
| AS P  | 80    | 100    | 7    | NBR |
| AS    | 80    | 100    | 7    | NBR |
| A     | 80    | 100    | 10   | NBR |
| AS    | 80    | 100    | 10   | NBR |
| A     | 80    | 100    | 10   | FKM |
| AS    | 80    | 100    | 10   | FKM |
| D5    | 80    | 100    | 10   | NBR |
| A DUO | 80    | 100    | 12   | NBR |
| AS    | 80    | 100    | 13   | NBR |
| AS    | 80    | 100    | 13   | FKM |
| A DUO | 80    | 100    | 14   | FKM |
| A     | 80    | 105    | 10   | NBR |

| Referencia | Ø int. | Ø ext. | Altura | Material |
|------------|--------|--------|--------|----------|
|------------|--------|--------|--------|----------|

|      |       |        |      |     |
|------|-------|--------|------|-----|
| A    | 80    | 105    | 12   | FKM |
| B    | 80    | 105    | 13   | NBR |
| A    | 80    | 110    | 10   | NBR |
| AS   | 80    | 110    | 10   | NBR |
| AS   | 80    | 110    | 10   | FKM |
| A    | 80    | 110    | 12   | FKM |
| A    | 80    | 115    | 12   | FKM |
| A    | 80    | 140    | 12   | NBR |
| AS   | 80,96 | 120,65 | 12,7 | NBR |
| A    | 82    | 105    | 12   | NBR |
| A    | 85    | 95     | 8    | NBR |
| A    | 85    | 105    | 10   | NBR |
| A    | 85    | 105    | 13   | NBR |
| A    | 85    | 110    | 7    | NBR |
| A    | 85    | 110    | 12   | NBR |
| AS   | 85    | 110    | 12   | NBR |
| A    | 85    | 110    | 12   | FKM |
| AS   | 85    | 110    | 12   | FKM |
| B    | 85    | 110    | 13   | NBR |
| BS   | 85    | 110    | 13   | FKM |
| AS P | 85    | 120    | 7,5  | NBR |
| AS P | 85    | 120    | 7,5  | FKM |
| A    | 85    | 120    | 12   | NBR |
| A    | 85    | 120    | 12   | FKM |
| AS   | 85    | 120    | 12   | FKM |
| AS   | 85    | 125    | 13   | NBR |
| A    | 85    | 126    | 12   | NBR |
| A    | 85    | 130    | 12   | NBR |
| AS   | 85    | 130    | 12   | NBR |
| AS   | 85    | 130    | 13   | FKM |
| A    | 85    | 140    | 12   | NBR |
| A    | 86    | 100    | 7    | FKM |
| A    | 88    | 110    | 12   | NBR |
| A    | 88,9  | 127    | 12,7 | NBR |
| A    | 90    | 105    | 10   | NBR |
| A    | 90    | 110    | 7    | NBR |
| A    | 90    | 110    | 10   | NBR |
| A    | 90    | 110    | 12   | NBR |
| AS   | 90    | 110    | 12   | NBR |
| A    | 90    | 110    | 12   | FKM |
| AS   | 90    | 110    | 12   | FKM |
| A    | 90    | 110    | 13   | NBR |
| AS   | 90    | 110    | 13   | FKM |
| A    | 90    | 115    | 9    | NBR |
| A    | 90    | 115    | 9    | FKM |
| A    | 90    | 115    | 13   | NBR |
| AS   | 90    | 117,5  | 12,5 | FKM |
| A    | 90    | 120    | 12   | NBR |
| A    | 90    | 120    | 12   | FKM |



A



AS



B



C



DINA



D5



A DUO



AS P

| Referencia | Ø int. | Ø ext. | Altura | Material |
|------------|--------|--------|--------|----------|
|------------|--------|--------|--------|----------|

|       |        |        |      |     |
|-------|--------|--------|------|-----|
| A     | 90     | 120    | 13   | NBR |
| A     | 90     | 120    | 13   | FKM |
| A     | 90     | 130    | 12   | NBR |
| A     | 92     | 120    | 13   | NBR |
| A     | 92     | 120    | 13   | FKM |
| D5    | 92,07  | 117,47 | 12,7 | NBR |
| A     | 93     | 115    | 13   | FKM |
| B     | 95     | 110    | 9    | FKM |
| A     | 95     | 110    | 10   | NBR |
| A     | 95     | 110    | 10   | FKM |
| A     | 95     | 115    | 12   | NBR |
| AS    | 95     | 115    | 13   | FKM |
| A     | 95     | 120    | 7    | NBR |
| A     | 95     | 120    | 12   | NBR |
| A     | 95     | 120    | 12   | FKM |
| AS    | 95     | 120    | 13   | FKM |
| AS    | 95     | 120    | 15   | NBR |
| A     | 95     | 125    | 12   | NBR |
| AS    | 95     | 125    | 12   | NBR |
| A     | 95     | 125    | 12   | FKM |
| AS    | 95     | 125    | 12   | FKM |
| AS    | 95     | 125    | 13   | FKM |
| A     | 96     | 112    | 10   | NBR |
| AS    | 100    | 115    | 9    | FKM |
| A     | 100    | 120    | 12   | NBR |
| AS    | 100    | 120    | 12   | NBR |
| A     | 100    | 120    | 12   | FKM |
| AS    | 100    | 120    | 12   | FKM |
| A     | 100    | 120    | 13   | FKM |
| A DUO | 100    | 120    | 13   | FKM |
| A     | 100    | 125    | 12   | NBR |
| A     | 100    | 125    | 12   | FKM |
| A     | 100    | 125    | 13   | FKM |
| A     | 100    | 130    | 12   | NBR |
| AS    | 100    | 130    | 12   | NBR |
| A     | 100    | 130    | 12   | FKM |
| AS    | 100    | 130    | 12   | FKM |
| A DUO | 100    | 130    | 13   | NBR |
| A DUO | 100    | 130    | 13   | FKM |
| A     | 100    | 130    | 14   | NBR |
| A     | 100    | 130    | 14   | FKM |
| A     | 100    | 135    | 13   | NBR |
| A     | 104    | 120    | 13   | FKM |
| A     | 104,77 | 136,39 | 12,7 | FKM |
| A     | 105    | 125    | 13   | NBR |
| AS    | 105    | 125    | 13   | NBR |
| A     | 105    | 125    | 13   | FKM |
| AS    | 105    | 125    | 13   | FKM |
| A     | 105    | 130    | 12   | NBR |

| Referencia | Ø int. | Ø ext. | Altura | Material |
|------------|--------|--------|--------|----------|
|------------|--------|--------|--------|----------|

|       |     |     |      |     |
|-------|-----|-----|------|-----|
| AS    | 105 | 130 | 12   | NBR |
| A     | 105 | 130 | 12   | FKM |
| AS    | 105 | 130 | 13   | FKM |
| A     | 105 | 130 | 15   | NBR |
| A     | 105 | 130 | 15   | FKM |
| A     | 105 | 140 | 12   | NBR |
| A     | 105 | 140 | 12   | FKM |
| D5    | 105 | 140 | 12   | NBR |
| A     | 110 | 130 | 8    | NBR |
| A     | 110 | 130 | 8    | FKM |
| A     | 110 | 130 | 12   | NBR |
| A     | 110 | 130 | 12   | FKM |
| AS    | 110 | 130 | 12   | FKM |
| A     | 110 | 130 | 13   | NBR |
| A     | 110 | 130 | 13   | FKM |
| A     | 110 | 130 | 14,5 | NBR |
| A     | 110 | 130 | 14,5 | FKM |
| A     | 110 | 140 | 10   | NBR |
| A     | 110 | 140 | 12   | NBR |
| A     | 110 | 140 | 12   | FKM |
| AS    | 110 | 140 | 12   | FKM |
| A     | 110 | 140 | 13   | NBR |
| A     | 110 | 140 | 13   | FKM |
| AS    | 110 | 145 | 13   | FKM |
| B     | 110 | 145 | 15   | FKM |
| D5    | 110 | 150 | 16   | NBR |
| A     | 112 | 140 | 13   | NBR |
| A     | 115 | 135 | 9    | FKM |
| A     | 115 | 140 | 10   | NBR |
| A     | 115 | 140 | 10   | FKM |
| A     | 115 | 140 | 12   | NBR |
| AS    | 115 | 140 | 12   | NBR |
| A     | 115 | 140 | 12   | FKM |
| AS    | 115 | 140 | 12   | FKM |
| AS    | 115 | 140 | 16   | NBR |
| A     | 115 | 150 | 12   | NBR |
| A     | 115 | 150 | 12   | FKM |
| AS    | 118 | 148 | 15   | NBR |
| A DUO | 118 | 150 | 15   | FKM |
| A     | 120 | 140 | 10   | FKM |
| A     | 120 | 140 | 13   | NBR |
| AS P  | 120 | 140 | 13   | NBR |
| A     | 120 | 140 | 13   | FKM |
| AS P  | 120 | 140 | 13   | FKM |
| A     | 120 | 150 | 12   | NBR |
| AS    | 120 | 150 | 12   | NBR |
| A     | 120 | 150 | 12   | FKM |
| AS    | 120 | 150 | 12   | FKM |
| D5    | 120 | 150 | 12,5 | NBR |

**A****AS****B****C****DINA****D5****A DUO****AS P**

| Referencia | Ø int. | Ø ext. | Altura | Material |
|------------|--------|--------|--------|----------|
|------------|--------|--------|--------|----------|

|    |        |        |      |     |
|----|--------|--------|------|-----|
| A  | 120    | 150    | 13   | NBR |
| A  | 120    | 150    | 13   | FKM |
| AS | 120    | 150    | 15   | NBR |
| AS | 120    | 150    | 15   | FKM |
| A  | 120    | 160    | 12   | NBR |
| A  | 120    | 160    | 12   | FKM |
| A  | 120    | 160    | 15   | NBR |
| A  | 120    | 160    | 15   | FKM |
| A  | 125    | 140    | 10   | NBR |
| A  | 125    | 140    | 10   | FKM |
| A  | 125    | 150    | 12   | NBR |
| AS | 125    | 150    | 12   | NBR |
| A  | 125    | 150    | 12   | FKM |
| AS | 125    | 150    | 12   | FKM |
| A  | 125    | 155    | 12   | NBR |
| AS | 125    | 155    | 12   | NBR |
| A  | 125    | 155    | 12   | FKM |
| AS | 125    | 155    | 12   | FKM |
| A  | 125    | 160    | 12   | NBR |
| A  | 125    | 160    | 12   | FKM |
| AS | 126    | 146    | 10   | NBR |
| A  | 127    | 152,4  | 12,7 | NBR |
| A  | 127    | 152,4  | 12,7 | FKM |
| A  | 128    | 150    | 13   | NBR |
| A  | 128    | 150    | 13   | FKM |
| A  | 128    | 158    | 20   | FKM |
| A  | 130    | 150    | 10   | NBR |
| A  | 130    | 150    | 10   | FKM |
| AS | 130    | 150    | 12   | NBR |
| AS | 130    | 150    | 12   | FKM |
| AS | 130    | 150    | 15   | NBR |
| AS | 130    | 155    | 12   | NBR |
| A  | 130    | 160    | 12   | NBR |
| A  | 130    | 160    | 12   | FKM |
| AS | 130    | 160    | 12   | FKM |
| A  | 130    | 160    | 13   | NBR |
| A  | 130    | 160    | 13   | FKM |
| A  | 130    | 160    | 15   | NBR |
| AS | 130    | 160    | 15   | NBR |
| A  | 130    | 160    | 15   | FKM |
| AS | 130    | 160    | 15   | FKM |
| A  | 130    | 165    | 15   | NBR |
| A  | 130    | 170    | 12   | NBR |
| A  | 130    | 170    | 12   | FKM |
| A  | 130    | 170    | 13   | NBR |
| A  | 130    | 170    | 13   | FKM |
| A  | 132,5  | 155,6  | 13   | NBR |
| B  | 134,54 | 155,57 | 9,52 | NBR |
| A  | 135    | 160    | 12   | NBR |

| Referencia | Ø int. | Ø ext. | Altura | Material |
|------------|--------|--------|--------|----------|
|------------|--------|--------|--------|----------|

|    |       |        |      |     |
|----|-------|--------|------|-----|
| A  | 135   | 160    | 12   | FKM |
| AS | 135   | 160    | 15   | FKM |
| A  | 135   | 170    | 12   | NBR |
| A  | 135   | 170    | 12   | FKM |
| A  | 138   | 160    | 15   | NBR |
| A  | 138   | 160    | 15   | FKM |
| B  | 140   | 160    | 13   | NBR |
| A  | 140   | 165    | 12   | NBR |
| A  | 140   | 165    | 15   | NBR |
| A  | 140   | 170    | 12   | NBR |
| AS | 140   | 170    | 12   | NBR |
| A  | 140   | 170    | 12   | FKM |
| AS | 140   | 170    | 12   | FKM |
| A  | 140   | 170    | 15   | NBR |
| A  | 140   | 170    | 15   | FKM |
| D5 | 140   | 175    | 16   | NBR |
| A  | 140   | 180    | 12   | NBR |
| A  | 140   | 180    | 12   | FKM |
| A  | 140   | 180    | 13   | NBR |
| A  | 140   | 180    | 13   | FKM |
| A  | 140   | 180    | 15   | NBR |
| A  | 140   | 180    | 15   | FKM |
| B  | 144   | 160    | 12   | NBR |
| A  | 145   | 175    | 15   | NBR |
| A  | 145   | 175    | 15   | FKM |
| A  | 145   | 180    | 12   | NBR |
| A  | 145   | 180    | 12   | FKM |
| A  | 145   | 180    | 13   | NBR |
| A  | 145   | 180    | 13   | FKM |
| A  | 145   | 180    | 14   | NBR |
| A  | 145   | 180    | 14   | FKM |
| A  | 148   | 170    | 14,5 | NBR |
| A  | 148   | 170    | 14,5 | FKM |
| A  | 150   | 170    | 12   | NBR |
| A  | 150   | 170    | 12   | FKM |
| A  | 150   | 180    | 12   | NBR |
| A  | 150   | 180    | 12   | FKM |
| A  | 150   | 180    | 13   | NBR |
| AS | 150   | 180    | 13   | NBR |
| A  | 150   | 180    | 13   | FKM |
| D5 | 150   | 180    | 13   | NBR |
| A  | 150   | 180    | 15   | NBR |
| A  | 150   | 180    | 15   | FKM |
| AS | 150   | 180    | 18   | NBR |
| AS | 152,4 | 187,32 | 19   | NBR |
| AS | 155   | 174    | 12   | NBR |
| A  | 155   | 175    | 12   | NBR |
| AS | 155   | 185    | 15   | FKM |



A



AS



B



C



DINA



D5



A DUO



AS P

| Referencia | ∅ int. | ∅ ext. | Altura | Material |
|------------|--------|--------|--------|----------|
|------------|--------|--------|--------|----------|

|      |        |        |      |     |
|------|--------|--------|------|-----|
| D5   | 155    | 195    | 16   | NBR |
| D5   | 155    | 195    | 16   | FKM |
| A    | 160    | 185    | 10   | NBR |
| A    | 160    | 185    | 10   | FKM |
| AS P | 160    | 190    | 8    | FKM |
| A    | 160    | 190    | 15   | NBR |
| AS   | 160    | 190    | 15   | NBR |
| A    | 160    | 190    | 15   | FKM |
| AS   | 160    | 190    | 15   | FKM |
| A    | 160    | 200    | 12   | NBR |
| B    | 160    | 200    | 15   | FKM |
| A    | 165    | 190    | 13   | NBR |
| A    | 165    | 190    | 13   | FKM |
| A    | 165    | 200    | 15   | NBR |
| A    | 170    | 190    | 15   | NBR |
| A    | 170    | 190    | 15   | FKM |
| A    | 170    | 200    | 12   | NBR |
| A    | 170    | 200    | 12   | FKM |
| A    | 170    | 200    | 15   | NBR |
| AS   | 170    | 200    | 15   | NBR |
| A    | 170    | 200    | 15   | FKM |
| AS   | 170    | 200    | 15   | FKM |
| D5   | 170    | 200    | 15   | NBR |
| D5   | 170    | 210    | 16   | NBR |
| A    | 175    | 200    | 15   | NBR |
| A    | 175    | 200    | 15   | FKM |
| A    | 175    | 210    | 14   | NBR |
| A    | 175    | 210    | 14   | FKM |
| A    | 180    | 200    | 13   | NBR |
| A    | 180    | 200    | 13   | FKM |
| AS   | 180    | 200    | 16   | FKM |
| A    | 180    | 210    | 15   | NBR |
| AS   | 180    | 210    | 15   | NBR |
| A    | 180    | 210    | 15   | FKM |
| AS   | 180    | 210    | 15   | FKM |
| A    | 180    | 215    | 16   | NBR |
| A    | 180    | 215    | 16   | FKM |
| A    | 180    | 220    | 15   | NBR |
| A    | 180    | 220    | 15   | FKM |
| A    | 184,15 | 222,25 | 14,2 | FKM |
| A    | 184,15 | 222,25 | 14,5 | NBR |
| A    | 185    | 210    | 13   | FKM |
| A    | 185    | 215    | 16   | NBR |
| D5   | 185    | 216,8  | 15,9 | NBR |
| AS   | 190    | 215    | 16   | NBR |
| A    | 190    | 220    | 15   | NBR |
| A    | 190    | 220    | 15   | FKM |
| A    | 190    | 225    | 16   | NBR |
| AS   | 190    | 225    | 16   | NBR |

| Referencia | ∅ int. | ∅ ext. | Altura | Material |
|------------|--------|--------|--------|----------|
|------------|--------|--------|--------|----------|

|    |     |        |      |     |
|----|-----|--------|------|-----|
| AS | 190 | 225    | 16   | FKM |
| AS | 190 | 230    | 16   | NBR |
| D5 | 190 | 230    | 16   | NBR |
| B  | 199 | 241,3  | 14   | NBR |
| A  | 200 | 225    | 15   | NBR |
| A  | 200 | 225    | 15   | FKM |
| A  | 200 | 230    | 13   | NBR |
| A  | 200 | 230    | 13   | FKM |
| A  | 200 | 230    | 15   | NBR |
| AS | 200 | 230    | 15   | NBR |
| A  | 200 | 230    | 15   | FKM |
| AS | 200 | 230    | 15   | FKM |
| D5 | 200 | 240    | 16   | NBR |
| D5 | 200 | 240    | 16   | FKM |
| A  | 200 | 250    | 15   | NBR |
| A  | 200 | 250    | 15   | FKM |
| A  | 205 | 230    | 16   | NBR |
| A  | 205 | 230    | 16   | FKM |
| A  | 210 | 240    | 15   | NBR |
| A  | 210 | 240    | 15   | FKM |
| A  | 210 | 250    | 15   | NBR |
| A  | 210 | 250    | 15   | FKM |
| A  | 210 | 250    | 15   | FKM |
| A  | 210 | 290    | 20   | NBR |
| AS | 210 | 290    | 20   | NBR |
| A  | 210 | 290    | 20   | FKM |
| AS | 210 | 290    | 20   | FKM |
| A  | 220 | 250    | 15   | NBR |
| AS | 220 | 250    | 15   | NBR |
| A  | 220 | 250    | 15   | FKM |
| A  | 220 | 255    | 16   | NBR |
| A  | 220 | 260    | 16   | NBR |
| A  | 220 | 260    | 16   | FKM |
| D5 | 220 | 260    | 16   | NBR |
| D5 | 220 | 270    | 16   | FKM |
| D5 | 227 | 277,81 | 25,4 | NBR |
| A  | 230 | 260    | 15   | NBR |
| AS | 230 | 260    | 15   | NBR |
| A  | 230 | 260    | 15   | FKM |
| AS | 230 | 260    | 15   | FKM |
| D5 | 230 | 270    | 16   | NBR |
| A  | 230 | 280    | 15   | NBR |
| A  | 230 | 280    | 15   | FKM |
| A  | 240 | 270    | 15   | NBR |
| A  | 240 | 270    | 15   | FKM |
| D5 | 240 | 270    | 15   | FKM |
| A  | 240 | 275    | 16   | NBR |
| A  | 240 | 280    | 15   | NBR |
| A  | 240 | 280    | 15   | FKM |
| A  | 250 | 280    | 15   | NBR |

**A****AS****B****C****DINA****D5****A DUO****AS P**

| Referencia | Ø int. | Ø ext. | Altura | Material |
|------------|--------|--------|--------|----------|
|------------|--------|--------|--------|----------|

|     |       |       |      |     |
|-----|-------|-------|------|-----|
| A   | 250   | 280   | 15   | FKM |
| A   | 260   | 300   | 20   | NBR |
| A   | 260   | 300   | 20   | FKM |
| D5  | 260   | 300   | 20   | NBR |
| A   | 265   | 290   | 16   | NBR |
| A   | 265   | 290   | 16   | FKM |
| D5  | 265   | 315   | 18   | NBR |
| D5  | 270   | 310   | 20   | NBR |
| A   | 280   | 310   | 15   | NBR |
| A   | 280   | 310   | 15   | FKM |
| A   | 280   | 320   | 20   | NBR |
| A   | 280   | 320   | 20   | FKM |
| AS  | 280   | 320   | 20   | FKM |
| D5  | 280   | 320   | 20   | NBR |
| A   | 280   | 350   | 16   | FKM |
| A   | 300   | 340   | 18   | NBR |
| A   | 300   | 340   | 18   | FKM |
| D5  | 300   | 340   | 18   | NBR |
| C   | 310   | 350   | 18   | FKM |
| D5  | 315   | 360   | 16   | NBR |
| A   | 320   | 360   | 20   | NBR |
| A   | 320   | 360   | 20   | FKM |
| C   | 320   | 360   | 20   | NBR |
| D5  | 330   | 374   | 20   | FKM |
| A   | 340   | 380   | 18   | NBR |
| A   | 340   | 380   | 18   | FKM |
| A   | 350   | 390   | 18   | NBR |
| A   | 350   | 390   | 18   | FKM |
| A   | 370   | 410   | 15   | NBR |
| A   | 370   | 410   | 15   | FKM |
| D5  | 370   | 410   | 20   | NBR |
| A   | 380   | 420   | 20   | NBR |
| AS  | 380   | 420   | 20   | NBR |
| A   | 380   | 420   | 20   | FKM |
| AS  | 380   | 420   | 20   | FKM |
| D5  | 380   | 440   | 25   | NBR |
| A   | 390   | 430   | 20   | NBR |
| A   | 390   | 430   | 20   | FKM |
| A   | 394   | 420   | 16   | NBR |
| AS  | 394   | 420   | 16   | NBR |
| A   | 394   | 420   | 16   | FKM |
| A   | 400   | 440   | 20   | NBR |
| A   | 400   | 440   | 20   | FKM |
| A P | 400   | 450   | 25   | NBR |
| D5  | 406,4 | 457,2 | 22,2 | NBR |
| A   | 420   | 460   | 20   | NBR |
| A   | 420   | 460   | 20   | FKM |
| C   | 420   | 460   | 20   | NBR |
| AS  | 420   | 470   | 20   | NBR |

| Referencia | Ø int. | Ø ext. | Altura | Material |
|------------|--------|--------|--------|----------|
|------------|--------|--------|--------|----------|

|    |     |     |    |     |
|----|-----|-----|----|-----|
| AS | 420 | 470 | 20 | FKM |
| A  | 440 | 480 | 20 | NBR |
| A  | 440 | 480 | 20 | FKM |
| A  | 450 | 500 | 22 | NBR |
| A  | 450 | 500 | 22 | FKM |
| A  | 480 | 520 | 20 | NBR |
| A  | 480 | 520 | 20 | FKM |
| A  | 500 | 540 | 20 | NBR |
| AS | 500 | 540 | 20 | NBR |
| A  | 500 | 540 | 20 | FKM |
| AS | 500 | 540 | 20 | FKM |
| D5 | 510 | 560 | 22 | NBR |
| D5 | 560 | 610 | 22 | FKM |

\* Lista de medidas sujeta a variaciones.



**Lidering, S.A.**

Pg. Ferrocarrils Catalans, 106 - 108  
08940 Cornellà de Llobregat BARCELONA  
Ventas Nacionales: 902 480 440  
Ventas Internacionales: +34 93 480 44 22  
Fax: 93 480 44 04

Pollensa, 2, Ofic. 8  
Edif. Artemisa - Tartessos  
28290 Las Rozas MADRID  
Tel: 902 480 440 Fax: 91 361 40 20

**Lidering, S.A.R.L.**

Parc des Aqueducs, Lot E  
Chemin du Favier RD 42  
69230 Saint-Genis-Laval FRANCE  
Tél: 04 72 67 02 67 Fax: 04 78 56 04 08

**Lidering, GmbH**

Schiessstraße, 55  
40549 Düsseldorf DEUTSCHLAND  
Tel. 00 34 93 480 44 22 Fax 00 34 93 480 44 04

**S.A. Lidering N.V.**

BP10 - 1410 Waterloo BELGIQUE - BELGIË  
Tél: 00 34 93 480 44 22 Fax: 00 34 93 480 44 04

<http://www.lidering.com>